

# Socket Weld x Threaded Coupling

**Material:** Available in a complete range of Carbon Steels, Stainless Steels, Alloy Steels and Non-ferrous metals certified to ASTM, ASME, and Military standards.

**Sizes:** 1/4" - 6" in CL 3000 • 1/4" - 6" in CL 6000 • 1/4" - 4" in CL 9000  
Also available in tube sizes, special pipe schedules/class rating, orifice holes, and special lengths

**Threads:** American National Standard Taper Pipe Threads NPT (ANSI/ASME B1.20.1-1983)  
Also available in other thread forms: NPTF, NPSC, NPSM, NGT, SAE, BSPT, BSPP and in any combination.  
Left hand threads available upon request.

## Welding Gap and Minimum Flat Dimension for Socket Weld Fittings

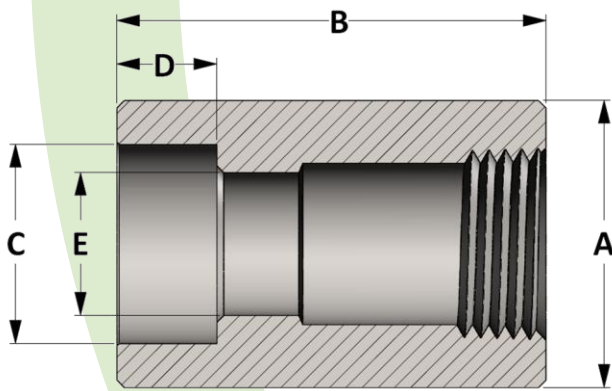
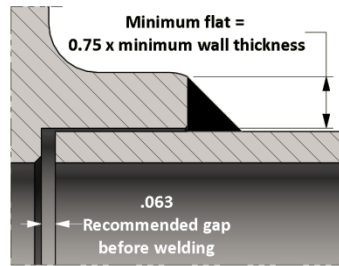

Active  
3D  
Model



All dimensions are in inches • Weights are based on Carbon Steel

PIPE SIZE	CLASS 3000 – Figure No. 30060											
	1/4	3/8	1/2	3/4	1	1-1/4	1-1/2	2	2-1/2	3	3-1/2	4
A	0.875	1.063	1.250	1.500	1.813	2.250	2.500	3.000	3.625	4.313	5.000	5.500
B	1.375	1.500	1.875	2.000	2.375	2.625	3.125	3.375	3.625	4.250	4.500	4.750
C	0.560	0.693	0.859	1.071	1.335	1.682	1.922	2.410	2.910	3.536	4.036	4.545
D	0.438	0.438	0.438	0.531	0.531	0.531	0.531	0.656	0.656	0.656	0.781	0.781
E	0.364	0.493	0.622	0.824	1.049	1.380	1.610	2.067	2.469	3.068	3.548	4.026
LBS	0.16	0.25	0.41	0.57	0.83	1.62	2.18	3.03	4.89	6.95	11.72	12.77

PIPE SIZE	CLASS 6000 – Figure No. 60060											
	1/4	3/8	1/2	3/4	1	1-1/4	1-1/2	2	2-1/2	3	3-1/2	4
A	1.000	1.250	1.500	1.750	2.000	2.500	2.750	3.625	4.250	5.000	6.000	6.000
B	1.375	1.500	1.875	2.000	2.375	2.625	3.125	3.375	3.625	4.250	4.500	4.750
C	0.560	0.693	0.859	1.071	1.335	1.682	1.922	2.410	2.910	3.536	4.046	4.545
D	0.438	0.438	0.438	0.531	0.531	0.531	0.531	0.656	0.656	0.656	0.781	0.781
E	0.250	0.359	0.466	0.614	0.815	1.160	1.338	1.689	2.125	2.625	2.728	3.438
LBS	0.26	0.40	0.70	0.93	1.96	2.38	4.30	4.10	10.29	16.22	26.89	23.89

PIPE SIZE	CLASS 9000 – Figure No. 90060											
	1/4	3/8	1/2	3/4	1	1-1/4	1-1/2	2	2-1/2	3	3-1/2	4
A	1.250	1.750	1.750	2.000	2.500	2.750	3.000	3.625	4.500	5.500	6.000	6.500
B	1.375	1.500	1.875	2.000	2.375	2.625	3.125	3.375	3.625	4.250	4.500	4.750
C	0.560	0.693	0.859	1.071	1.335	1.682	1.922	2.410	2.910	3.536	4.036	4.545
D	0.438	0.438	0.438	0.531	0.531	0.531	0.531	0.656	0.656	0.656	0.781	0.781
E	0.064	0.171	0.252	0.434	0.599	0.896	1.100	1.503	1.771	2.300	2.728	3.438
LBS	0.42	0.92	1.05	1.89	2.93	3.57	7.26	6.67	11.58	20.14	23.84	27.47