

TAPPED ANGLE BRACKET

Steel

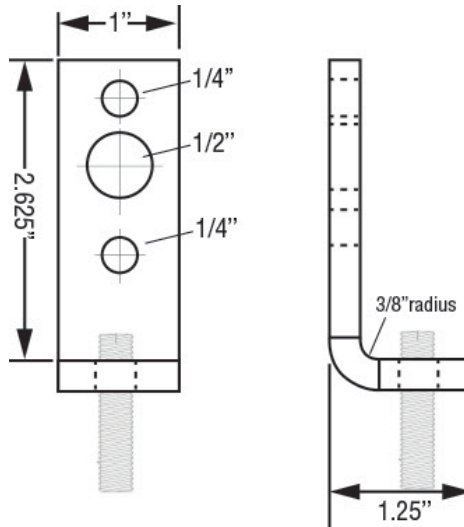

- Surface Finish: Electro-zinc plated
 - Pre-threaded structural attachment fastened to wall or the side of a joist to support hanger rod
 - Conforms with Federal Specification WW-H-171, Manufacturers Standardization Society ANSI/MSS-SP-58; install in accordance with ANSI/MSS-SP-69
- Material: Carbon Steel
Finish: Pre-Galvanized

Item #	Description	ROD SIZE	MAX. LOAD CAPACITY	BOX QTY	ERICO®
2530258A	Tapped Angle Bracket (Pre-Galvanized)	3/8"-16	560#	300	2370037EG

ANGLE BRACKET

Steel

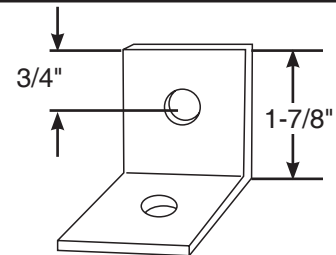

Designed for use with wood, steel or concrete beams to provide a means for supporting hanger rod.

- Size Range: 3/8" & 1/2" rod sizes
 - Surface Finish: Electro-zinc plated, Black
 - Structural attachment fastened to the wall or the side of a joist to support hanger rod
 - Conforms with Federal Specification WW-H-171 (Type 35), Manufacturers Standardization Society ANSI/MSS-SP-58 (Type 34); install in accordance with ANSI/MSS-SP-69
- Finish: Pre-Galvanized

Item #	Description	MAX. LOAD CAPACITY	MAX. LOAD CAPACITY BOLT TO STEEL	BOX QTY	TOLCO®
2530255	Angle Bracket 3/8" x 3/8"	650#	1150#	150	013828
2530256	Angle Bracket 1/2" x 1/2"	650#	1150#	50	013866

System No.		Location		Spec Section		Paragraph	
Submitted By		Date		Approved		Date	

TAPPED ANGLE BRACKET WITH KNURLED NUT

Steel



Function: Practical and economical bracket used to support piping from wood, concrete or steel beams.

Features: Unique design allows rod to be easily threaded into bracket.
 Offset design permits unlimited rod adjustment.
 Center mounting hole will accept 3/8" and 1/2" fastener bolts.

Per NFPA 13: 1/2" thru 2" pipe requires 3/8" fastener,
 2-1/2" thru 4" pipe requires 1/2" fastener.

Size Range: 3/8" rod, pipe sizes 1/2" thru 4"
 Material: Carbon Steel
 Finish: Pre-Galvanized

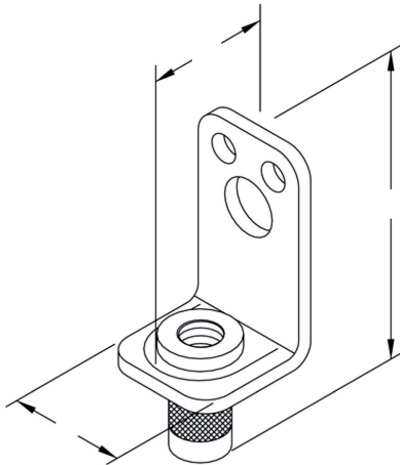

Item #	ROD SIZE	LOAD CAPACITY	WEIGHT EA.	CROSS REFERENCE TOLCO:
25-30-259	3/8"	300#	.14 LB	TYPE 58

System No.		Location		Spec Section		Paragraph	
Submitted By		Date		Approved		Date	