

# Bronze Y-pattern Swing Check Valve



Threaded Connection • 300 WOG • Class 150



T-511

### Features

- Constructed of 85-5-5-5 bronze
- Can be installed in the vertical or horizontal position

### Approvals

- MSS SP-80
- ANSI B1.20.1

### Valve Seat Rating

300 WOG - 150 WSP

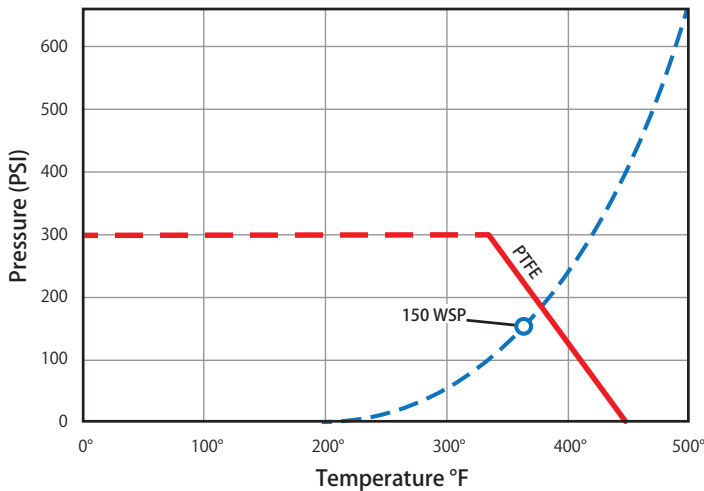

Install 5 pipe diameter minimum downstream from pump discharge or changes in direction to avoid flow turbulence. Flow straighteners may be required in extreme cases.

Note: On pump discharge, the preferred check valves are: inline, spring assisted, center-guided, lift checks.

Jomar Check Valves may be installed in both horizontal and vertical lines with upward flow or in an intermediate position. They will operate satisfactory in a declining plane (no more than 15°).

**Warning: Do Not Use For Reciprocating Air Compressor Service**

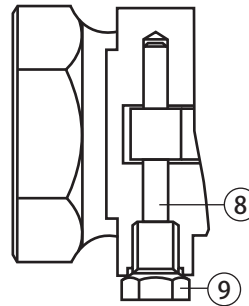
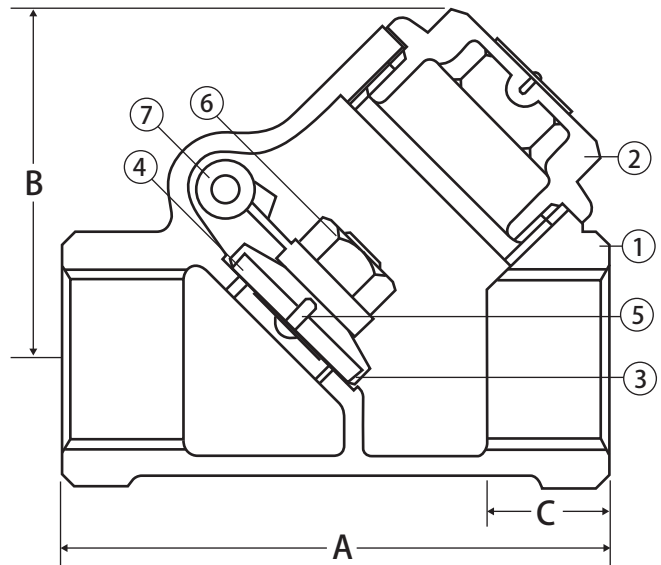

### Material Specifications

No.	Part	Materials
1	Body	Bronze
2	Cap	Bronze
3	Disc	Bronze
4	Seat	PTFE
5	Seat Screw	Brass
6	Seat Nut	Brass
7	Hinge Arm	Bronze
8	Hinge Pin	Brass
9	Hinge Screw	Brass

### Dimensions

Part No.	Size	A	B	C
105-303	1/2"	2.36	1.77	0.54
105-304	3/4"	2.76	1.97	0.57
105-305	1"	3.40	2.28	0.70
105-306	1-1/4"	3.78	2.67	0.71
105-307	1-1/2"	4.57	2.95	0.75
105-308	2"	5.35	3.70	0.79
105-309	2-1/2"	6.72	4.65	1.14
105-310	3"	7.55	5.47	1.18



**WARNING:** This product can expose you to chemicals including lead, which is known to the State of California to cause cancer, and lead, which is known to the State of California to cause birth defects or other reproductive harm. For more information go to [www.P65Warnings.ca.gov](http://www.P65Warnings.ca.gov).