

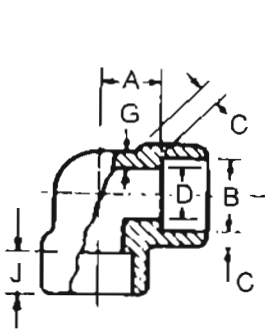

# SOCKET-WELDING FITTINGS

ASME B16.11-1996 (REVISION OF ASME B16.11-1991)



90° ELBOW

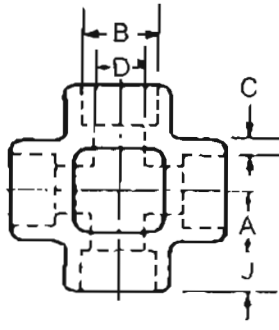

CROSS

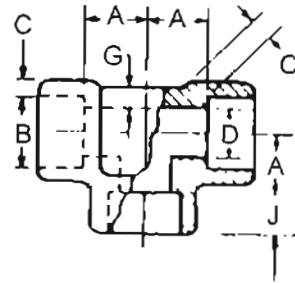

TEE

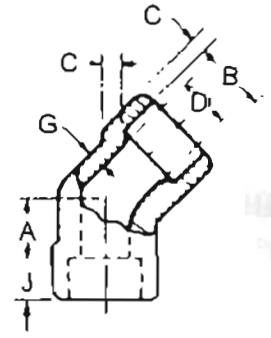

45° ELBOW

DN	Nom. Pipe Size	Socket Bore Dia. (2) B	Bore Diameter of Fittings(2) D			Socket Wall Thickness(1) C						Body Wall Thickness G			Depth of Socket Min. J
						Class Designation						Class Designation			
			Class Designation			3000		6000		9000		3000	6000	9000	
			3000	6000	9000	Ave.	Min.	Ave.	Min.	Ave.	Min.	Min.	Min.	Min.	
6	1/8	11.2	7.6	4.8		3.18	3.18	3.96	3.43			2.41	3.15		9.5
		10.8	6.1	3.2											
8	1/4	14.6	10.0	7.1		3.78	3.30	4.60	4.01			3.02	3.68		9.5
		14.2	8.5	5.6											
10	3/8	18.0	13.3	9.9		4.01	3.50	5.03	4.37			3.20	4.01		9.5
		17.6	11.8	8.4											
15	1/2	22.2	16.6	12.5	7.2	4.67	4.09	5.97	5.18	9.35	8.18	3.73	4.78	7.47	9.5
		21.8	15.0	11.0	5.6										
20	3/4	27.6	21.7	16.3	11.8	4.90	4.27	6.96	6.04	9.78	8.56	3.91	5.56	7.82	12.5
		27.2	20.2	14.8	10.3										
25	1	34.3	27.4	21.5	16.0	5.69	4.98	7.92	6.93	11.38	9.96	4.55	6.35	9.09	12.5
		33.9	25.9	19.9	14.4										
32	1-1/4	43.1	35.8	30.2	23.5	6.07	5.28	7.92	6.93	12.14	10.62	4.85	6.35	9.70	12.5
		42.7	34.3	28.7	22.0										
40	1-1/2	49.2	41.6	34.7	28.7	6.35	5.54	8.92	7.80	12.70	11.12	5.08	7.14	10.15	12.5
		48.8	40.1	33.2	27.2										
50	2	61.7	53.3	43.6	38.9	6.93	6.04	10.92	9.50	13.84	12.12	5.54	8.74	11.07	16.0
		61.2	51.7	42.1	37.4										
65	2-1/2	74.4	64.2			8.76	7.67					7.01			16.0
		73.9	61.2												
80	3	90.3	79.4			9.52	8.30					7.62			16.0
		89.8	76.4												
100	4	115.7	103.8			10.69	9.35					8.56			19.0
		115.2	100.7												

NOTES:

(1) Average of Socket Wall Thickness around periphery shall be no less than listed values.

The minimum values are permitted in localized areas.

(2) Upper and lower values for each size are the respective maximum and minimum dimensions.

(3) DIMENSIONAL TOLERANCES: see page 17



# SOCKET-WELDING FITTINGS

ASME B16.11-1996 (REVISION OF ASME B16.11-1991)

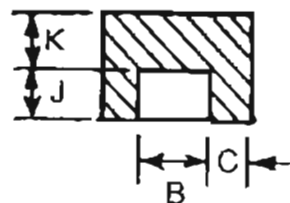
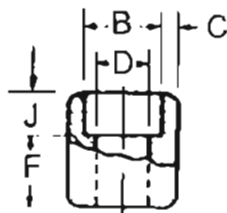
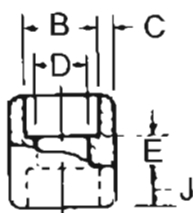

COUPLING

HALF COUPLING

CAP

Dimensions in Millimeters.

Center to Bottom of Socket-A						Laying Lengths		Tolerances $\pm$			End Wall Thickness K Min.			Nom. Pipe Size	DN
90° Elbows Tees, Crosses			45° Elbows			Couplings E	Half Couplings F	A	E	F	Class Designation				
3000	6000	9000	3000	6000	9000						3000	6000	9000		
11.0	11.0		8.0	8.0		6.5	16.0	1.0	1.5	1.0	4.8	6.4		1/8	6
11.0	13.5		8.0	8.0		6.5	16.0	1.0	1.5	1.0	4.8	6.4		1/4	8
13.5	15.5		8.0	11.0		6.5	17.5	1.5	3.0	1.5	4.8	6.4		3/8	10
15.5	19.0	25.5	11.0	12.5	15.5	9.5	22.5	1.5	3.0	1.5	6.4	7.9	11.2	1/2	15
19.0	22.5	28.5	13.0	14.0	19.0	9.5	24.0	1.5	3.0	1.5	6.4	7.9	12.7	3/4	20
22.5	27.0	32.0	14.0	17.5	20.5	12.5	28.5	2.0	4.0	2.0	9.6	11.2	14.2	1	25
27.0	32.0	35.0	17.5	20.5	22.5	12.5	30.0	2.0	4.0	2.0	9.6	11.2	14.2	1-1/4	32
32.0	38.0	38.0	20.5	25.5	25.5	12.5	32.0	2.0	4.0	2.0	11.2	12.7	15.7	1-1/2	40
38.0	41.0	54.0	25.5	28.5	28.5	19.0	41.0	2.0	4.0	2.0	12.7	15.7	19.0	2	50
41.0			28.5			19.0	43.0	2.5	5.0	2.5	15.7	19.0		2-1/2	65
57.0			32.0			19.0	44.5	2.5	5.0	2.5	19.0	22.4		3	80
66.5			41.0			19.0	48.0	2.5	5.0	2.5	22.4	28.4		4	100

NOTES:

(1) Average of Socket Wall Thickness around periphery shall be no less than listed values.

The minimum values are permitted in localized areas.

(2) Upper and lower values for each size are the respective maximum and minimum dimensions.

(3) DIMENSIONAL TOLERANCES: see page 17



H-Thrd's  
Minimum 4 Full Thrd's  
Engagement Class 2A/2B Fit  
ANS1 B1.1

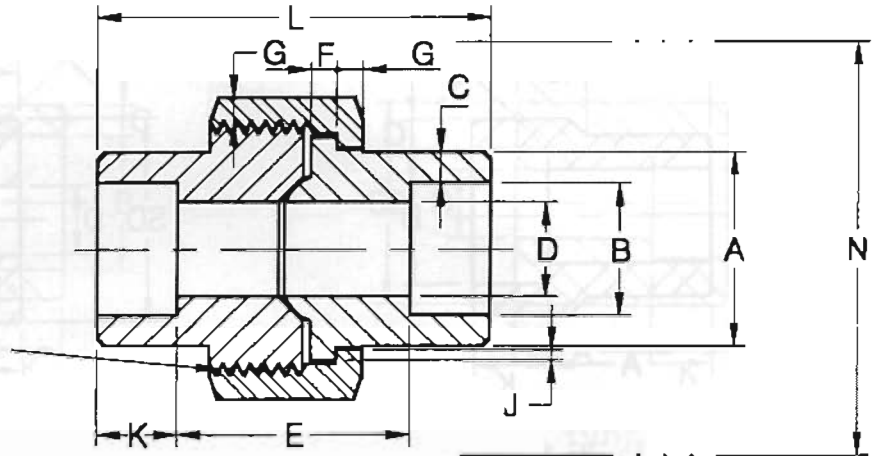

Dimensions in Millimeters.

Nom. Pipe Size	Pipe End Min. A	Socket Bore Dia. B	Socket Wall Min. C	Water Way Bore D	Laying Length E	Male Flange Min. F	Nut Min. G	Thrds. Per 25.4mm Max. H	Bearing Min. J	Depth of Socket Min. K	Length of Assem. Nom. L	Clear Assem. Nut N
1/8	21.8	10.92 10.67	3.17	6.83 6.43	22.4 19.0	3.17	3.17	16	1.24	9.6	41.4	49.0
1/4	21.8	14.22 13.97	3.30	9.85 9.45	22.4 19.0	3.17	3.17	16	1.24	9.6	41.4	49.0
3/8	25.9	17.78 17.53	3.48	13.92 13.51	26.9 20.6	3.43	3.43	14	1.37	9.6	46.0	55.0
1/2	31.2	21.84 21.59	4.06	17.47 17.07	26.9 20.6	3.68	3.68	14	1.50	9.6	49.0	57.0
3/4	37.1	27.18 26.92	4.27	21.79 21.39	31.8 25.4	4.06	4.06	11	1.68	12.7	56.9	67.0
1	45.5	34.04 33.78	4.95	28.14 27.74	34.3 26.2	4.57	4.44	11	1.85	12.7	62.0	79.0
1-1/4	54.9	42.67 42.42	5.28	35.76 35.36	40.6 32.5	5.33	5.21	11	2.13	12.7	71.1	94.0
1-1/2	61.5	48.77 48.51	5.54	41.61 41.20	42.2 34.0	5.84	5.59	10	2.31	12.7	76.5	111.0
2	75.2	61.47 61.21	6.05	52.53 52.12	45.5 37.3	6.60	6.35	10	2.69	15.8	86.1	132.0
2-1/2	91.7	74.17 73.66	7.65	64.72 64.31	61.7 52.1	7.49	7.11	8	3.07	15.8	102.4	148.0
3	109.2	90.17 89.66	8.31	77.67 77.27	63.8 53.6	8.25	8.00	8	3.53	15.8	109.0	175.0



# REDUCER INSERTS

SOCKET WELDING MSS-SP-79-1992

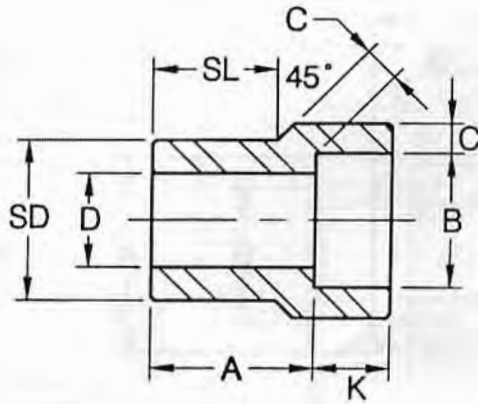

TYPE 1

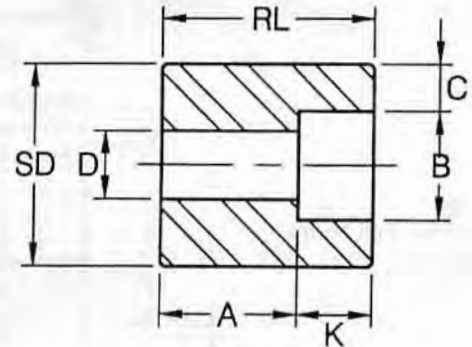

TYPE 2<sup>(1)</sup>

Dimensions in Millimeters.

Nom. Pipe Size	Type(2)		Socket		Shank Dia. SD	Laying Length A		Bore D		Wall Min. C		Length			
			Dia. B	Depth Min. K		3M	6M	3M	6M	3M	6M	SL		RL(Min)	
	3M	6M										3M	6M	3M	6M
3/8 x 1/4	1	1	14.35	10	17.15	19	21	9.0	6.5	3.78	4.60	14	16		
1/2 x 3/8	1	1	17.78	10	21.34	21	23	12.5	9.0	4.01	5.03	16	16		
1/2 x 1/4	1	1	14.35	10	21.34	21	21	9.0	6.5	3.78	4.60	16	16		
3/4 x 1/2	1	1	21.97	10	26.67	22	25	16.0	11.5	4.67	5.97	17	19		
3/4 x 3/8	2	1	17.78	10	26.67	16	22	12.5	9.0	4.01	5.03		19	27	
3/4 x 1/4	2	2	14.35	10	26.67	18	22	9.0	6.5	3.78	4.60			27	32
1 x 3/4	1	1	27.31	13	33.40	24	28	21.0	15.5	4.90	6.96	19	21		
1 x 1/2	2	1	21.97	10	33.40	16	28	16.0	11.5	4.67	5.97		21	28	
1 x 3/8	2	2	17.78	10	33.40	18	22	12.5	9.0	4.01	5.03			28	33
1 x 1/4	2	2	14.35	10	33.40	19	24	9.0	6.5	3.78	4.60			28	33
1-1/4 x 1	1	1	34.04	13	42.16	25	30	26.5	20.5	5.69	7.92	21	22		
1-1/4 x 3/4	2	2	27.31	13	42.16	18	21	21.0	15.5	4.90	6.96			32	35
1-1/4 x 1/2	2	2	21.97	10	42.16	19	22	16.0	11.5	4.67	5.97			32	35
1-1/4 x 3/8	2	2	17.78	10	42.16	21	24	12.5	9.0	4.01	5.03			32	35
1-1/4 x 1/4	2	2	14.35	10	42.16	22	25	9.0	6.5	3.78	4.60			32	35
1-1/2 x 1-1/4	1	1	42.80	13	48.26	28	35	35.0	29.5	6.07	7.92	22	25		
1-1/2 x 1	2	1	34.04	13	48.26	18	29	26.5	20.5	5.69	7.92		25	33	
1-1/2 x 3/4	2	2	27.31	13	48.26	19	25	21.0	15.5	4.90	6.96			33	40
1-1/2 x 1/2	2	2	21.97	10	48.26	21	27	16.0	11.5	4.67	5.97			33	40
1-1/2 x 3/8	2	2	17.78	10	48.26	22	28	12.5	9.0	4.01	5.03			33	40
2 x 1-1/2	1	1	48.90	13	60.32	32	39	41.0	34.0	6.35	8.9	25	28		
2 x 1-1/4	2	2	42.80	13	60.32	21	24	35.0	29.5	6.07	7.92			38	41
2 x 1	2	2	34.04	13	60.32	22	25	26.5	21.0	5.69	7.92			38	41
2 x 3/4	2	2	27.31	13	60.32	24	27	21.0	15.5	4.90	6.96			38	41
2 x 1/2	2	2	21.97	10	60.32	25	28	16.0	11.5	4.67	5.97			38	41

(1) At the option of the manufacturer Type 2 Reducers may be furnished in Type 1 configuration.

(2) 3M & 6M symbols denote 3000 and 6000 classes.