

# data sheet



**GUARANTEED**

## Brass Ball Valve (Lead Free)

- 600 lb. WOG, 150 lb. WSP
- Full Port IPS and CxC (Sweat)
- Forged brass body
- Chrome plated ball
- c UPC listed (1/4-2) Threaded & Soldered
- UL Listed (1/4-2) Threaded & Soldered
- CSA Approved (1/4-2) Threaded
- Approved under ANSI/ASMI

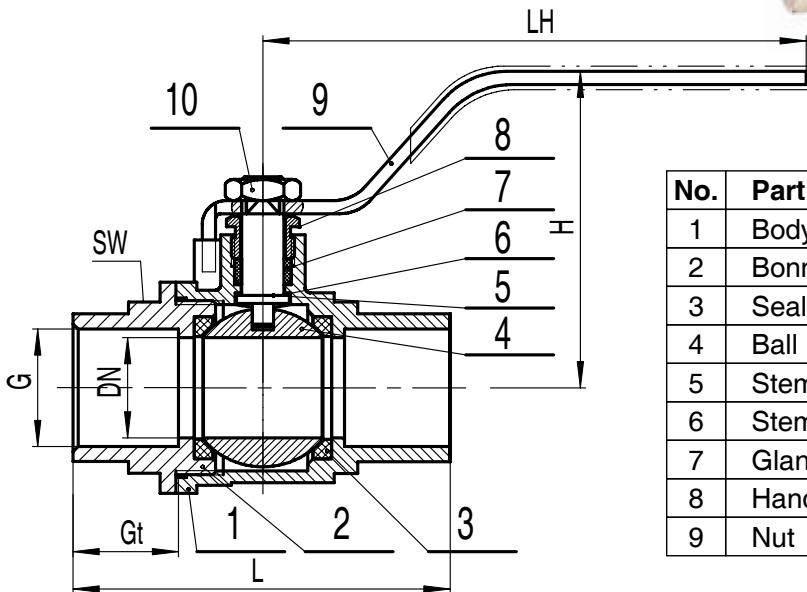

No.	Part Name	Material	Remarks
1	Body	C46500	
2	Bonnet	C46500	
3	Seal	Teflon - PTFE	
4	Ball	C37700	Chrome-Plated
5	Stem	C46500	Copper Alloy Rod
6	Stem Packing	Teflon - PTFE	
7	Gland Screw	C37700	Copper Alloy Rod
8	Handle	Steel	Zinc-Plated
9	Nut	C37700	

	G	DN	L	H	SW	Gt	LH
1/2	15.93 <sup>+0.09</sup>	14.5	57.5	50.5	22.5	15	89
3/4	22.28 <sup>+0.09</sup>	19	71.5	60	30	20	104
1	28.66 <sup>+0.09</sup>	24.5	88	62.5	36	26	117
1-1/4	35.01 <sup>+0.09</sup>	32	106	70	44	30	117
1-1/2	41.36 <sup>+0.1</sup>	40	116	94	50	30	145
2	54.06 <sup>+0.1</sup>	50	136	102	64	35	145

The information contained herein is produced in good faith and is believed to be reliable but is for guidance only. ARGCO and its agents cannot assume liability or responsibility for results obtained in the use of its product by persons whose methods are outside or beyond our control. It is the user's responsibility to determine the suitability of any of the products, methods of use, or preparation prior to use, mentioned in our literature. It is the user's responsibility to observe and adapt such precautions as may be advisable for the protection of personnel and property in the handling and use of any of our products.

**FOR MORE INFORMATION CALL ARGCO AT 1-800-854-1015  
OR LOG ONTO WWW.ARGCO.COM**