

Brass Ball Valve



2 Piece • Full Port • Threaded Connection • 600 WOG



JF-100T

CRN# 0C16654.5

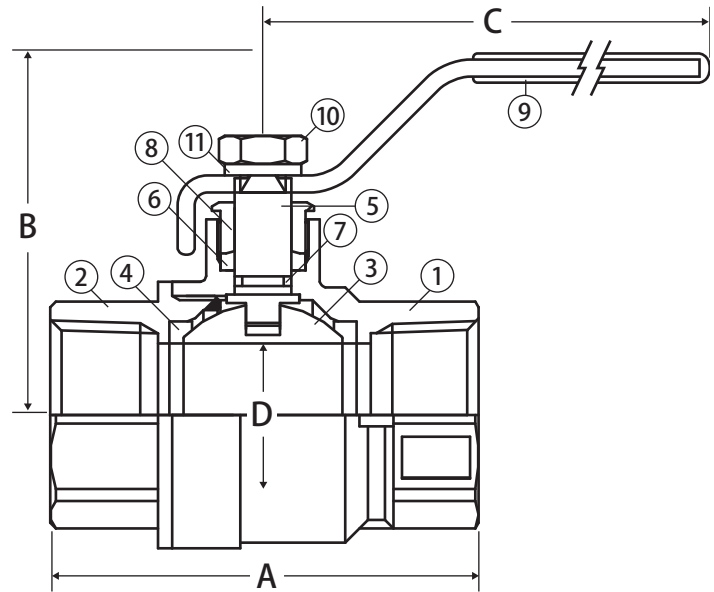

Features

- Gland follower and single o-ring stem design
- Blow-out proof stem
- 100% leak tested

Approvals



- UL Listed up to 600 PSI (1/4" - 1"), 300 PSIG (1-1/4" - 2", 250 PSIG (2-1/2" - 4")
 - MHKZ - Manual valves
 - YRPV - Gas shutoff valves
 - YQNZ - Compressed gas shutoff valves
 - YRBX - Flammable liquid shutoff valves
 - YSDT - LP gas shutoff valves
- CSA Certified
 - CGA 3.16 (125 PSIG)
 - ANSI Z21.15 (.5 PSIG)
 - CGA CR91 (5 PSIG)
 - ASME B16.44 (5 PSIG)
 - ASME B16.33 (125 PSIG) (1/2" - 2")
 - ASME B16.38 (125 PSIG) (2-1/2" - 4")
- FM Approval (1/4" - 2")
- MSS SP-110
- ANSI B1.20.1

Valve Seat Rating

600 WOG - 150 WSP

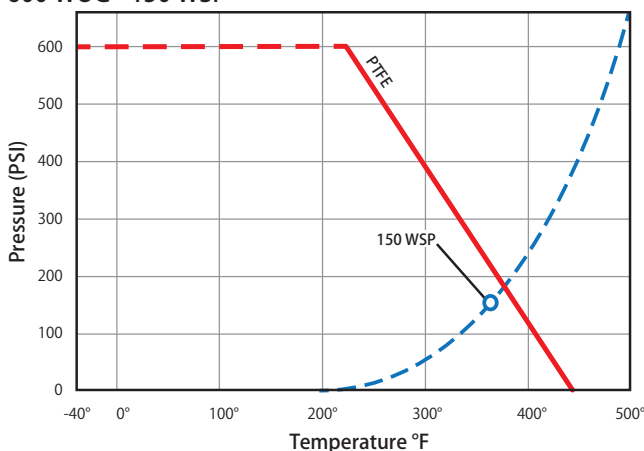

Material Specifications

No.	Part	Materials
1	Body	Brass - C37700
2	End Connection	Brass - C37700
3	Ball	Chrome Plated Brass - C37700
4	Seat (2)	PTFE
5	Stem*	Brass - C37700
6	Packing	PTFE
7	Stem O-ring	Buna-N
8	Packing Gland	Brass - C37700
9	Handle	Steel - Chrome Plated
10	Handle Nut	Steel - Chrome Plated
11	Lock Washer	Steel - Chrome Plated

* 3" and 4" have 304 stainless steel stem

Dimensions

Part No.	Size	A	B	C	D	Cv
100-101	1/4"	1.73	1.69	3.35	0.39	7.7
100-102	3/8"	1.73	1.69	3.35	0.39	7.8
100-103	1/2"	2.28	1.81	3.35	0.59	16.8
100-104	3/4"	2.52	2.36	4.29	0.75	34.8
100-105	1"	2.97	2.52	4.29	0.98	52.2
100-106	1-1/4"	3.44	2.52	5.63	1.26	112.5
100-107	1-1/2"	3.88	2.72	5.63	1.57	174.0
100-108	2"	4.29	3.03	5.63	1.97	255.2
100-109	2-1/2"	5.59	4.25	7.76	2.52	350.3
100-110	3"	6.34	4.92	8.37	2.95	563.7
100-111	4"	7.83	5.85	9.25	3.90	879.3

WARNING: This product can expose you to chemicals including lead, which is known to the State of California to cause cancer, and lead, which is known to the State of California to cause birth defects or other reproductive harm. For more information go to www.P65Warnings.ca.gov.