



5930

How to use your 5930 Actuated Ball Valve (Installation, Operation and Maintenance Instructions).



GENERAL INFORMATION

Overview:

- RWV 5930 valve is a low torque ON/OFF ball valve specifically designed to be used with an actuator.
- The valve is full port and feature blow-out proof stem

Features:

- Full port design
- Blow out proof stem, allowing unmounting of the actuator even with pressure in the line
- Female threaded NPT end connections as per ANSI/ASME B1.20.1

PRESSURE AND TEMPERATURE VALVE RATINGS

Non shock pressure at temperature range	Non shock pressure at max. temperature
600 psi from 15°F(*) to 160°F	150 psi at 250°F (**)

(*) = below freezing temperatures only for water with antifreeze additives.

(**) = over 212°F only for water with anti-boiling additives.

The operative conditions shown above are intended for non-shock operating conditions: water hammers, impacts, stress loads, corrosive or erosive external environmental elements and the transport of fluids with abrasive properties should be avoided.

INSTALLATION

Prior to installation, verify the valve is suitable for the pressures, temperatures, operating fluids and environment in which it will be installed. It is the responsibility of the installer and/or of the facility designer to ensure that the application does not exceed the limits of pressure and temperature of the valve and is carried out in accordance with local current laws and regulations.

Valve can be installed in any position (vertical, horizontal, inclined) providing the stem is pointing upward.

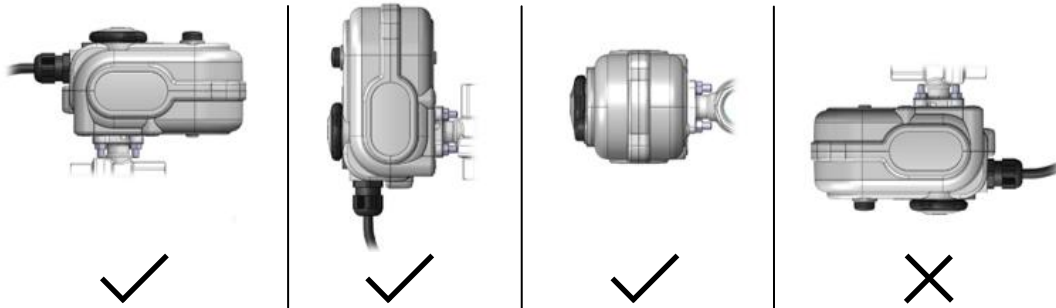

Flow can go in both directions. The position chosen for the installation should allow for accessibility to the valve during operation, inspection and maintenance.

Pipe ends should be void of any burrs and not protrude inside the bore or obstruct any part of the flow (it's advisable to flush the line after installation or after performing maintenance on the system).

Do not subject the valve to any torsion, bending or tension. We recommend the use of pipe brackets. Pipe brackets should be installed at a distance suitable to properly support the valve. Do not to overload the valve with any unexpected additional stresses

Threaded connections

The valves shall be installed on pipes using, if necessary, a sealant suitable for the application and the expected type of fluid.

- The pipe threading shall be MNPT in accordance ANSI/ASME B1.20.1. The pipe threading must be free of damage that could impair the correct coupling with the valve and the outward seal.
- Additional stresses on the body to body-end junction must be avoided during installation. A pipe clamp or key wrench must always grasp onto the hexagon/octagon portion of the threaded end that needs to be screwed to the pipe. In order to avoid additional stress on the valve be careful not to tighten the pipe at an excessive distance from the threaded area.
- Avoid screwing pipes too far into the valve. This could result in damage to the valve seats, resulting in leakage once the valve is operational.

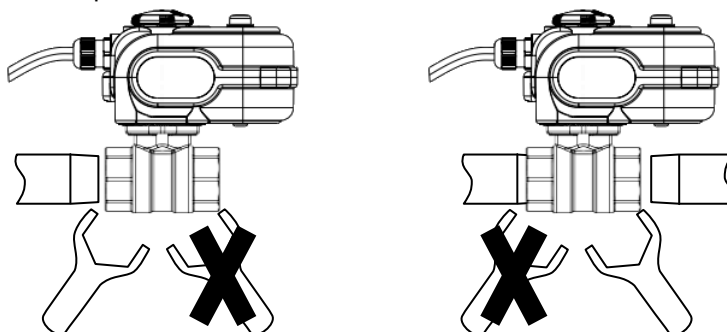

WIRING DIAGRAM

Actuator must be connected to power supply according the wiring diagram below. Similar diagram is also printed on the side of the actuator.

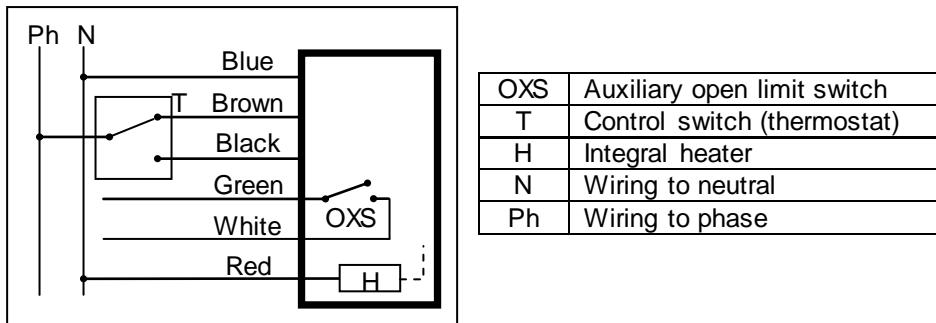

MANUAL OVERRIDE

The valve can be manually operated without the need to remove the actuator:

- Rise the manual handle (a)
- Declutch the actuator by pressing the button (b);
- While keeping the button (b) pressed maneuver the actuator as needed (c);

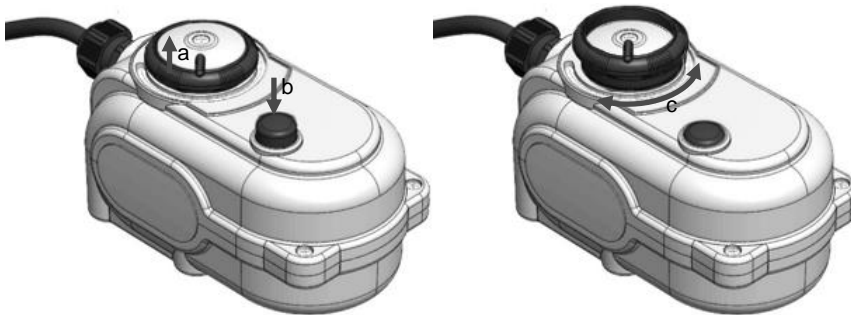

USE AND MAINTENANCE

Valves need to be operated on a regular basis (at least 6 times a year) with a complete open/close cycle. Beyond routine periodic cycling no additional maintenance is required

Valves must be replaced in case of leakages and/or damages, actuators shall not be dismantled from the valves without written consent from RWV. The valves have been designed and manufactured to be exclusively used as shut-off valves, therefore they shall be used in the fully open or fully closed position only. They must be operated only through the actuator provided by RWV.

RWV declines any direct or indirect responsibility in case of improper use, tampering, modification or dismantling of the valves. The improper use, tampering and/or modification on any part of the valve, voids the warranty and liability for any failure or damage as well as any applicable Certification.

For more information, feel free to contact RED-WHITE VALVE CORP.

RED-WHITE VALVE CORP.

20600 Regency Lane
 Lake Forest, CA 92630
 redwhitevalvecorp.com
 Tel 800.222.RWVC(7982)
 Fax 949.859.7200