

BI-METAL HOLE SAWS



ARGCO's bi-metal hole saws are constructed of hardened, heat resistant high speed steel teeth, exhibiting exceptional strength & durability.

Variable pitch all-purpose hole saws cut through wood, metal, or plastic and can be used in a wide variety of applications from production and maintenance to the electrical and building trades.

ITEM #	DESCRIPTION
3010401A	Holesaw 5/8"
3010402A	Holesaw 11/16"
3010403A	Holesaw 3/4"
3010405A	Holesaw 7/8"
3010407A	Holesaw 1"
3010408A	Holesaw 1-1/16"
3010409A	Holesaw 1-1/8"
3010410A	Holesaw 1-3/16"
3010411A	Holesaw 1-1/4"
3010413A	Holesaw 1-3/8"
3010414A	Holesaw 1-7/16"
3010415A	Holesaw 1-1/2"
3010416A	Holesaw 1-9/16"
3010417A	Holesaw 1-5/8"
3010419A	Holesaw 1-3/4"
3010421A	Holesaw 1-7/8"
3010422A	Holesaw 2"
3010424A	Holesaw 2-1/8"
3010425A	Holesaw 2-1/4"
3010427A	Holesaw 2-3/8"
3010428A	Holesaw 2-1/2"
3010430A	Holesaw 2-5/8"
3010431A	Holesaw 2-3/4"
3010433A	Holesaw 3"
3010437A	Holesaw 3-1/2"
3010441A	Holesaw 4"
3010445A	Holesaw 4-1/2"
3010490A	1L Arbor
3010491A	2L Arbor
3010493A	4L Arbor
3010494A	5L Arbor
3010495A	6L Arbor
3010496A	4321 PD pilot bit
3010497A	56 PD pilot bit

System No.		Location		Spec Section		Paragraph	
Submitted By		Date		Approved		Date	

PIPE CENTERING PUNCH

- Magnetic center punch and level combination accurately locates position of holes to be drilled into pipe.
- Prevents drill bit from “walking” on curved surface of pipe
- No need for pipe clamp
- Two vials for horizontal or vertical leveling
- 1” to 10” pipe capacity

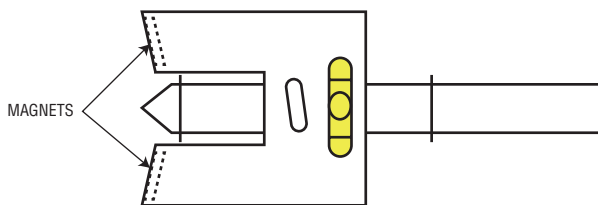
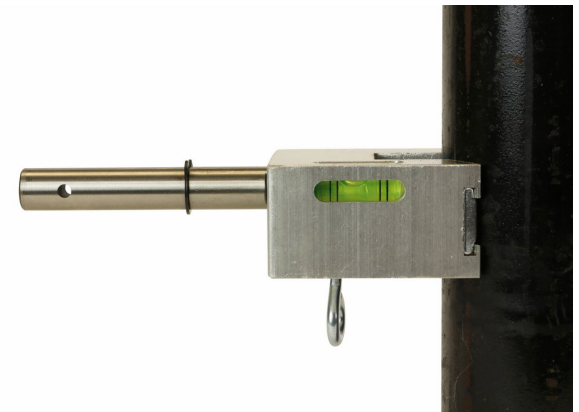
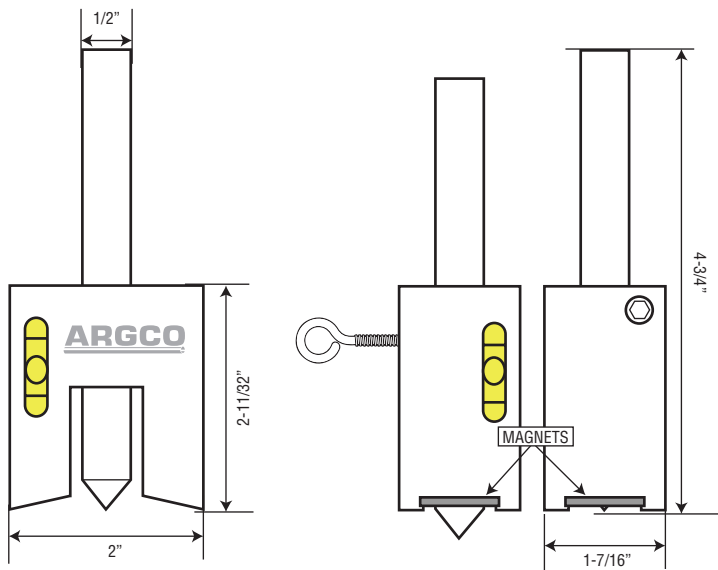

item # 3099106
ON CENTER
PIPE HOLE CUTTING PUNCH

System No.		Location		Spec Section		Paragraph	
Submitted By		Date		Approved		Date	