

**\* Maximum Operating Conditions**

Temperature (°F)	Maximum Pressure PSI
	12" & Smaller
170°	Up to 225
180°	Up to 200
190°	Up to 175
200°	Up to 150
210°	Up to 125
220°	Up to 100
230°	Up to 75

Contact factory for other elastomers. Not for steam applications.

**NOTES:**

WWW.ENGINEEREDFLEX.COM FOR INSTALLATION INSTRUCTIONS. JOINT MUST BE INSTALLED AT ITS NEUTRAL LENGTH. BOLTS MUST BE PROPERLY TORQUED. NOT SUITABLE FOR STEAM APPLICATIONS. **IF CONNECTING PIPE IS NOT ANCHORED AND GUIDED, CONTROL RODS MUST BE USED.**

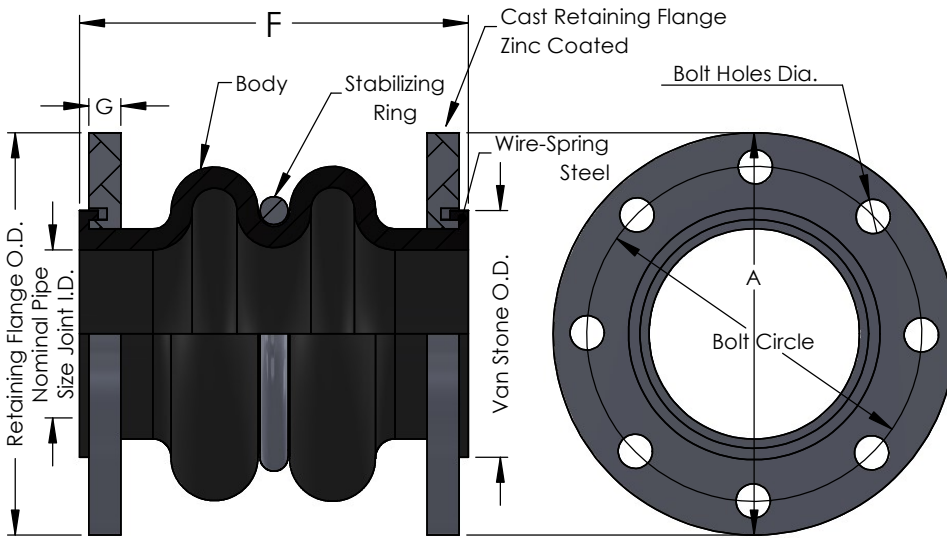

**\*\*When installing against a raised face flange - the use of a ring gasket is recommended.\*\***

PIPE SIZE	Dimensions			Bolting			Movements				Physical			Approx. Weights			Materials			
	Pipe Size-Joint I.D.	F-Length of Joint	G-Flange Width	A-Flange/Ring O.D.	Flange Bolt Hole Circle	Number & Hole Size	Axial Compression	Axial Extension	Lateral Deflection	Angular Movements	Pressure Rating (PSIG)*	Vacuum Rating (In/Hg)	Temperature Rating*	Expansion Joint (lbs)	Control Unit Set (2)	Total Approx. wght (lbs)	Tube Elastomer	Cover Elastomer	Body Fabric	Body Reinforcing
2"	2"	7"	.63"	6"	4.75"	4 - .75"	2"	1.188"	1.75"	45°	225	26	230°F	9	-	9	Neoprene	Neoprene	Nylon	Fabric
2.5"	2.5"	7"	.71"	7"	5.5"	4 - .75"	2"	1.188"	1.75"	43°	225	26	230°F	13.3	-	13.3	Neoprene	Neoprene	Nylon	Fabric
3"	3"	7"	.71"	7.5"	6"	4 - .75"	2"	1.188"	1.75"	38°	225	26	230°F	14.3	-	14.3	Neoprene	Neoprene	Nylon	Fabric
4"	4"	9"	.71"	9"	7.5"	8 - .75"	2"	1.375"	1.562"	34°	225	26	230°F	20.3	-	20.3	Neoprene	Neoprene	Nylon	Fabric
5"	5"	9"	.79"	10"	8.5"	8 - .88"	2"	1.375"	1.562"	29°	225	26	230°F	24.5	-	24.5	Neoprene	Neoprene	Nylon	Fabric
6"	6"	9"	.87"	11"	9.5"	8 - .88"	2"	1.375"	1.562"	25°	225	26	230°F	29.5	-	29.5	Neoprene	Neoprene	Nylon	Fabric
8"	8"	13"	.87"	13.5"	11.75"	8 - .88"	2.375"	1.375"	1.375"	19°	225	26	230°F	43.8	-	43.8	Neoprene	Neoprene	Nylon	Fabric
10"	10"	13"	.95"	16"	14.25"	12-1"	2.375"	1.375"	1.375"	15°	225	26	230°F	65.5	-	65.5	Neoprene	Neoprene	Nylon	Fabric
12"	12"	13"	.95"	19"	17"	12-1"	2.375"	1.375"	1.375"	13°	225	26	230°F	95	-	95	Neoprene	Neoprene	Nylon	Fabric
14"	14"	13.75"	1.02"	21"	18.75"	12-1.13"	1.75"	1.118"	1.118"	9°	150	26	230°F	115	-	115	Neoprene	Neoprene	Nylon	Fabric

WARNING: Control units must be used to protect this part from excessive movement if piping is not properly anchored. Expansion joints may operate in pipelines or equipment carrying fluids and/or gases at elevated temperature and pressures. Normal precautions should be taken to make sure these parts are installed correctly and inspected regularly. Precautions should be taken to protect personnel in the event of leakage or splash.

**NSF 372 - LEAD FREE**

The wetted surface of this product contacted by consumable water contains less than one quarter of one percent (0.25%) of lead by weight. Material complies with state codes and standards, where applicable, requiring reduced lead content.

REV. \_\_\_\_\_ DRAWN BY: CL \_\_\_\_\_ Date: 10/10/2019



5331 Quam Ave NE  
St. Michael, MN 55376  
Phone: 763-201-2151  
Fax: 763-201-2134  
Email: sales@engineeredflex.com

Style: **(302 SERIES) DOUBLE SPHERE EXP. JOINTS**

SCALE: NONE DRAWING NUMBER: \_\_\_\_\_

CUSTOMER: \_\_\_\_\_

PROJECT: \_\_\_\_\_

## Table 6: Control Units/Unanchored

Control Units must be installed when pressures (test • design • surge • operating) exceed rating below:

Pipe Size	Series 301 P.S.I.G.	Series 302 P.S.I.G.
1" thru 4"	180	135
5" thru 10"	135	135
12" thru 14"	90	90
16" thru 24"	45	45
30"	35	35

## Table 7: Maximum Surge or Test Pressure of the System

Nominal Pipe Size Expansion Joint I.D. Inch /(mm)	Number of Control Rods Recommended			
	2	4	6	8
1 (25)	949	•	•	•
1.25 (32)	830	•	•	•
1.5 (40)	510	•	•	•
2 (50)	661	•	•	•
2.5 (65)	529	•	•	•
3 (75)	441	•	•	•
4 (100)	311	622	•	•
5 (125)	235	470	•	•
6 (150)	186	371	•	•
8 (200)	163	326	•	•
10 (250)	163	325	488	•
12 (300)	160	320	481	•
14 (350)	112	223	335	•
16 (400)	113	227	340	453
18 (450)	94	187	281	375
20 (500)	79	158	236	315
24 (600)	74	147	221	294
30 (750)	70	141	211	281

Note:

Pressures listed above do not relate to the actual design pressure of the expansion joint products, but are the maximum surge or pressure for a specific control rod nominal pipe size.