

# Resilient Seat Knife Gate

Model # 59C - CF8 (304SS)

Model # 59F - CF8M (316SS)

Model # 59D - Ductile Iron

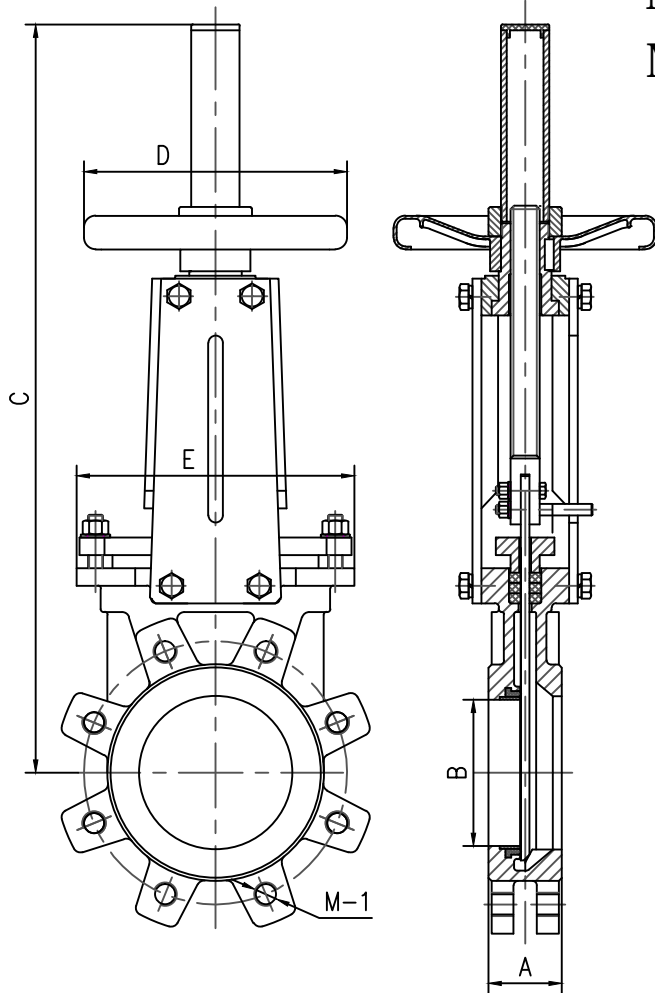

Part Name	Material - 59C	Material - 59F	Material - 59D
Body	CF8	CF8M	Ductile Iron
Gate	SS304	SS316	SS304
Seat retainer ring	SS304	SS316	SS304
Seat	EPDM	EPDM	EPDM
Packing	PTFE+Silicone	PTFE + Silicone	PTFE + Silicone
Gland	CF8	CF8M	Ductile Iron
Stem	SS304	SS304	SS420
Yoke	A36 Carbon Steel	A36 Carbon Steel	A36 Carbon Steel
Stem Nut	AL Bronze	AL Bronze	AL Bronze
Hand Wheel	Carbon Steel	Carbon Steel	Carbon Steel

Seat Options		
Fig# Designation	Material	Maximum Working Temperature
B	BUNA	175 F
E	EPDM	250 F
V	VITON	375 F
T	TEFLON	400 F

Designed and tested to conform with Tappi TIS 405-8 and MSS-SP81 standards. Flanges match ANSI B16.5

Maximum working pressure: 150CWP

Size	A	B	M-1(UNC)	C	D	E	WGT
in							lbs
4	2.00	3.94	8-M5/8"-11	20.15	7.87	7.48	27
5	2.25	4.94	8-M3/4"-10	22.44	8.66	8.34	34
6	2.25	5.94	8-M3/4"-10	26.18	9.84	9.05	47
8	2.75	7.88	8-M3/4"-10	32.48	11.81	11.25	64

