

## Clevis Hanger with Insulation Saddle System Fig. 260 ISS & Fig. 260R ISS

**Size Range:** 1/2" through 12" pipe and accommodates up to 2" of insulation.

**Material:** Carbon steel with high impact glass reinforced polypropylene saddle and carbon steel pipe spacer.

**Finish:** Plain or 8" & Smaller: Zinc Plated (Hot-Dip Galvanized optional), 10" & Larger: Hot-Dip Galvanized with Zinc Plated Bolts & Nuts

**Service:** Recommended for the suspension of stationary insulated chilled or hot water pipe lines.

**Maximum Temperature:** 40° F to 200° F

**Approvals:** Dual Fire Ratings, UL E94 V, and ASTM E84 Class 125/60.

**Installation:** Hanger load nut above clevis must be tightened securely to assure proper performance. Position the pipe on the saddle. Notch insulation to fit around the saddle. Square cut adjoining insulation and butt the insulation ends to each other. Insulation joint is coated, caulked and taped following standard insulation practice used on flanges and valves.

**Adjustment:** Vertical adjustment without removing the hanger may be made 7/8" through 2 3/8" varying with the size of the clevis. Tighten all nuts after adjustment.

**Features:** V-Block design cradles pipe through out the entire erection process. Clevis bolt spacer included as standard keeps the clevis lower strap from collapsing.

**Eliminates:**

- Wood blocks and standard shields
- Costly calcium silicate inserts
- Re-leveling of piping at each individual hanger after insulation is completed.

**Ordering:** Fig. Number (Fig. 260 ISS or Fig. 260R ISS for reduced rod size hole). Specify size number, pipe size, insulation thickness and finish.

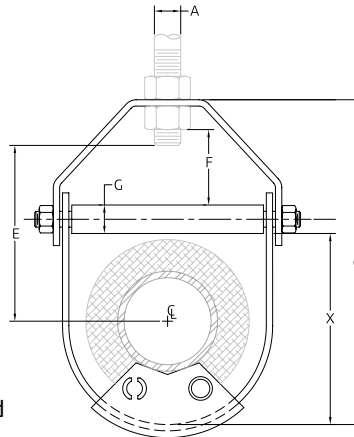

2" through 16"  
Patent #7,281,689

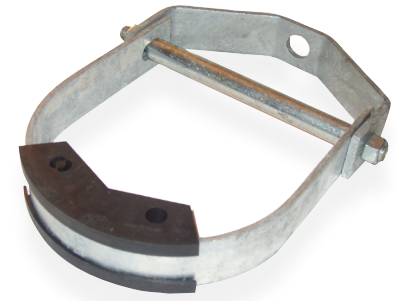

Fig. 260 ISS & 260R ISS Sizing Table

Pipe Size	Insulation Thickness				
	1/2"	3/4"	1"	1 1/2"	2"
	(Size Number)				
1/2	2	2	3	—	—
3/4	2	3	3	—	—
1	2	3	3	—	—
1 1/2	3	4	4	—	—
2	4	4	5	—	—
2 1/2	5	5	5	6	8
3	5	5	5	6	8
3 1/2	5	6	6	8	8
4	6	6	8	8	8
5	8	8	8	10	10
6	10	10	10	10	10
8	12	12	12	12	12
10	14	14	14	14	16
12	16	16	16	16	—

260 ISS & 260R ISS: Dimensions (in) • Loads (lbs) • Weight (lbs)

260 ISS Size Number	*Max Load	Weight	260 ISS Rod Size A	260R ISS Rod Size A	C	**Rod Take Out E	Adjust. F	G	X
2	550	0.73	3/8	3/8	4 1/2	2 5/8	7/8	1/4	2 3/8
3		1.32	1/2		6 1/2	4 1/16	1 7/16	3/8	3 5/8
4		1.83	5/8		7 13/16	4 1/2	1 1/2		4 1/2
5	750	2.44	1/2	8 15/16	5 1/2	1 3/4	1/2	5 11/16	
6		3.81		10 1/4	5 3/4	1 1/2		6 11/16	
8	1100	5.60	3/4	12 11/16	7 3/16	1 3/4	5/8	8 13/16	
10		9.73	7/8	15 1/4	8 7/16	1 7/8		10 3/4	
12		13.80	5/8	17 15/16	10 1/8	2 9/16		12 7/16	
14	1700	15.60	1	19 9/16	10 11/16	2 1/2	3/4	14 7/16	
16		26.81		22	12	2 3/8		1	16 5/16

\*Max load exceeds dead weight load requirement of pipe at max span, except 14 and 16 where max load is based on industry standard spacing of 14. Further information on typical pipe spans and piping weight per length can be found in the technical data section of the pipe hanger catalog.

\*\*Based on maximum insulation thickness, variations due to pipe size and insulation thickness may occur.

Fig. 260 ISS & 260R ISS Sizing Table

Copper Tube Size	Insulation Thickness				
	1/2"	3/4"	1"	1 1/2"	2"
	(Size Number)				
3/8	2	2	3	—	—
1/2	2	2	3	—	—
5/8	2	2	3	—	—
3/4	2	2	3	—	—
1	2	3	3	—	—
1 1/4	3	3	3	—	—
1 1/2	3	3	4	—	—
2	4	4	4	—	—
2 1/2	4	5	5	6	—
3	5	5	5	6	8
3 1/2	5	5	6	8	8
4	6	6	8	8	8
5	8	8	8	8	10
6	8	10	10	10	10
8	10	10	12	12	12

PROJECT INFORMATION	APPROVAL STAMP
Project:	Approved
Address:	Approved as noted
Contractor:	Not approved
Engineer:	Remarks:
Submittal Date:	
Notes 1:	
Notes 2:	

## Clevis Hanger with Insulation Saddle System (cont.) Fig. 260 ISS & Fig. 260R ISS

### Application:

ASC's insulation saddle system clevises are fully tested and rated for a temperature range from 40°F to 200°F. Ideal for the suspension of stationary insulated chilled or hot water pipelines.

### Chilled Water Testing:

Extensive field-testing and inspection has been performed to confirm that the integrity of the insulation vapor barrier for chilled water systems are sustained with the the 260 ISS and 260R ISS.

### To Assure Proper Vapor Barrier:

Each insulation joint should be properly coated, caulked and taped. Applying standard insulation practice that is used on flanges and valves.

### Features:

The Anvil 260 ISS and 260R ISS Insulation Saddle System reduces your overall installation time and greatly simplifies the way you insulate copper and steel pipe systems. Contractors can support insulated pipe with less parts and labor.

The revolutionary design of the 260 ISS and 260R ISS spread the load evenly over the lower strap of the clevis. The innovative V-Block design cradles the pipe at the design elevation throughout the erection process. The wide base V-Block design accommodates multiple pipe sizes, reducing the on-site inventory and the flexibility of pipe and insulation combinations with each size number.

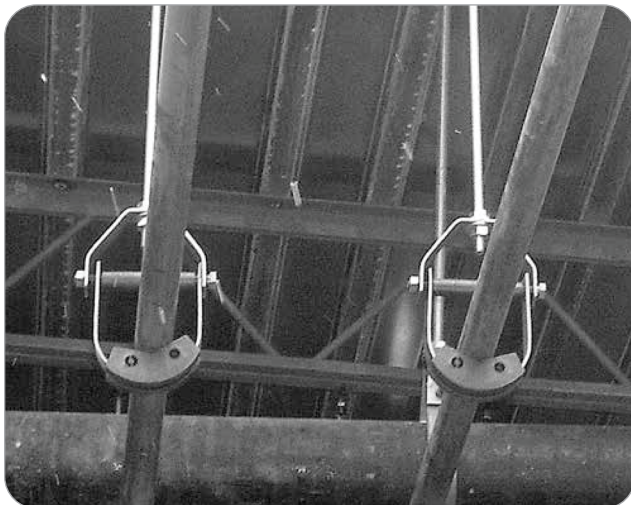
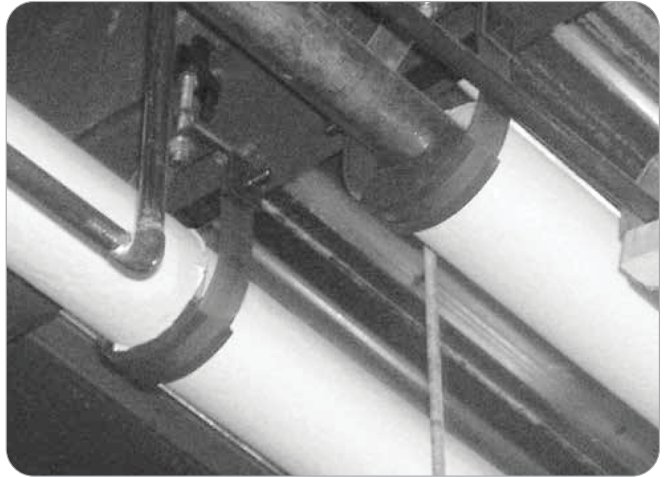

### ASTM & UL Fire Ratings:

The 260 ISS and 260R ISS have been independently tested by ASTM and UL for:

- Flame Spread Index (FSI)
- Smoke Development (SD) and drip ratings

Approvals from both agencies with the highest ratings for the type of product.

### Low Thermal Conductivity:

V-Block low thermal conductivity of .77 BTU-In./Sq.FT-Hr°F.

### Insulation R-Values:

The Figs. 260 ISS and 260R ISS polymer V-Block component has an R-value ranging from 5.0 to 8.7, depending on the hanger size. Meets or exceeds most commercial insulation R-values.

## Clevis Hanger with Insulation Saddle System (cont.) Fig. 260 ISS & Fig. 260R ISS

### Easy Installation

Make sure the double hex nuts installed with the upper hanger load nut above the clevis are tightened securely. Position pipe on saddle.

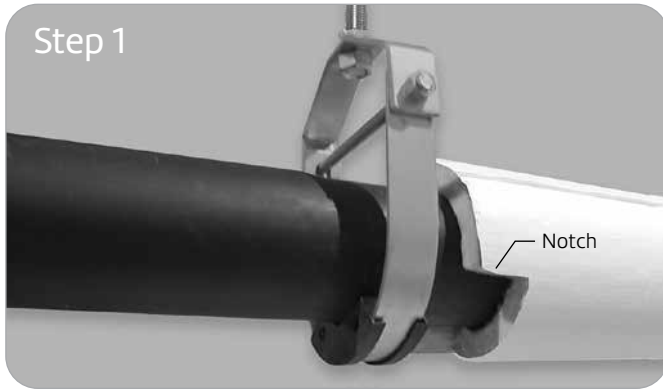

Step 1

Cope or notch insulation to fit around saddle. The notch should be deep enough to extend 1/8" to 1/4" beyond the saddle.

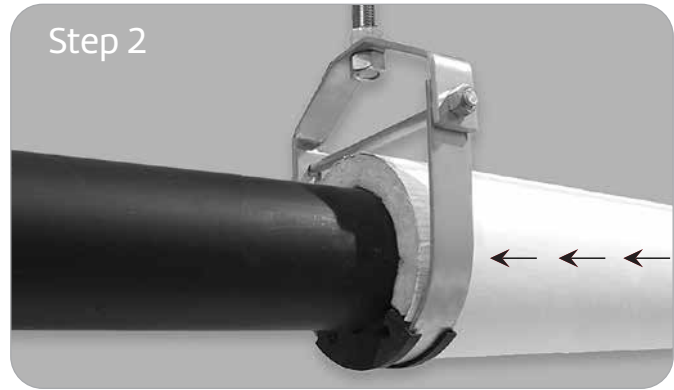

Step 2

Slide the notched insulation section over saddle.

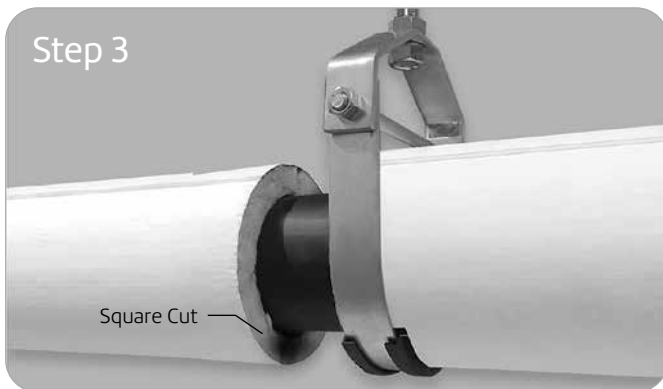

Step 3

Square cut adjoining insulation and butt the insulation ends to each other.



Step 4

Caulk joints and finish taping.

#### To assure proper vapor barrier:

Each insulation joint should be properly coated, caulked and taped. Applying standard insulation practice that is used on flanges and valves. Finish via standard taping method.

#### For chilled systems a mastic for thermal insulations or similar sealant is typically used:

Systems (50°F or greater) apply sealant to:

- The coped and flat edges of the mating insulation sections.
- The V-Block saddle at the insulation interface.

Systems (Below 50°F) apply sealant as per 50 Degrees with additional sealant to:

- The V-Block saddle joint between the two saddle halves.



Mastic applied to V-Block saddle at insulation interface. (50°F or greater).



Additional sealant applied to V-Block saddle joint between the two saddle halves. (Chilled water below 50°F).