

Feature

- 600# WOG
- Lead free brass body
- Full port
- Adjustable packing
- Compression ends
- Blow-out proof stem
- Chrome plated ball
- Virgin PTFE seats
- MSS-SP-110
- AB1953, NSF/ANSI 61 & 372 certified



Pressure/ Temperature rating	
600 psi from 15 °F to 160 °F	150 psi max. at 200 °F

Material

	Part	Material	Specification
1	Body	Lead Free Brass	ASTM B927 C28450
2	End piece	Lead Free Brass	ASTM B927 C28450
3	Ball	Lead Free Brass / Cr plated	ASTM B927 C28450
4	Seat	PTFE	PTFE
5	Stem	Lead Free Brass	ASTM B927 C28450
6	O-ring	FKM	-
7	Packing	PTFE	PTFE
8	Packing nut	Brass	ASTM B124 C37700
9	Handle	Steel	A36
10	Handle nut	Steel / Zn plated	A36
11	Compression Nut	NBR	NSF approved
12	Ferrule	Brass	ASTM B124 C37700

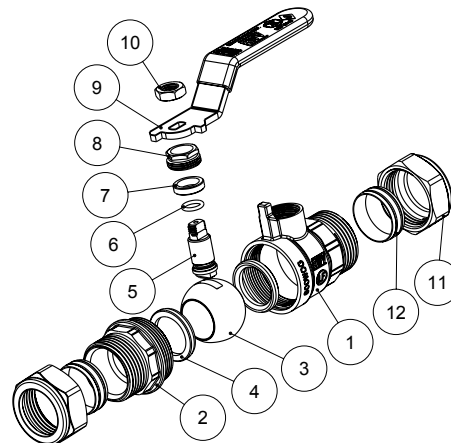

Dimension, Weight

Size	Φ [in]	A [in]	A1 [in]	C [in]	H [in]	L [in]	P [in]	Wt. [lb]
½"	0.627-0.631	2.81	2.16	0.50	1.93	3.59	0.50	0.52
¾"	0.877-0.881	3.20	2.50	0.55	2.06	3.59	0.73	0.72
1"	1.128-1.131	3.84	3.00	0.63	2.35	4.97	0.94	1.20

