

Dual Plate Iron Check Valve

Feature

- 150# WOG
- Cast iron body
- Dual plate discs
- Wafer style body
- Stainless steel discs
- EPDM seat

Pressure/ Temperature rating	
150# WOG	180 °F max. temp.



Material

	Part	Material	Specification
1	Body	Cast Iron	A126-B
2	Disc (plate)	Stainless Steel	ASTM A276 S30400
3	Spring	Stainless steel	ASTM A313 S31600
4	Hinge pin	Stainless steel	ASTM A276 S30400
5	Stop pin	Stainless steel	ASTM A276 S30400
6	Plug	Steel	-
7	Body washer	PTFE	PTFE
8	Spring washer	PTFE	PTFE
9	Eye bolt ¹	Steel	ASTM A307-A
10	Seat	EPDM	-

¹ Only on 6"-12"

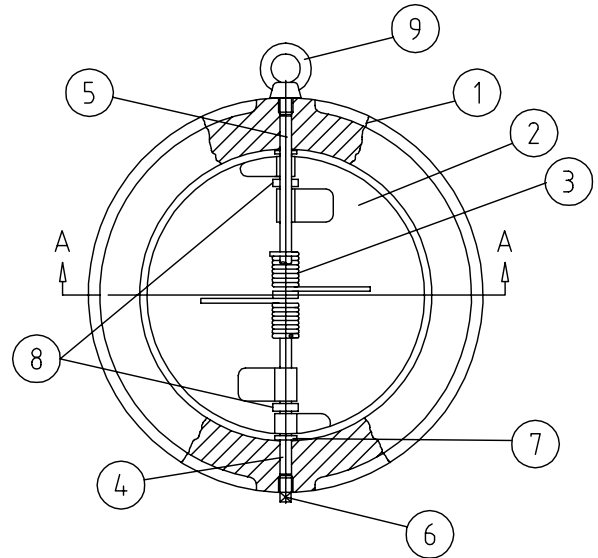

Dimension, Weight

Size	ΦA [in]	ΦE [in]	B [in]	GR [in]	F [in]	Weight [lb]
2"	4.02	2.56	1.69	1.13	0.75	4
2-1/2"	4.76	3.15	1.81	1.42	0.79	5
3"	5.24	3.70	2.52	1.71	1.10	7
4"	6.73	4.61	2.52	0.23	1.06	11
5"	7.60	5.71	2.76	2.59	1.18	14
6"	8.62	6.69	2.99	3.09	1.22	20
8"	10.87	8.82	3.50	4.11	1.30	38
10"	13.27	10.43	4.49	5.00	1.97	61
12"	15.98	12.20	4.49	5.83	1.69	116

