

Feature

- 125# WSP
- 200# WOG
- Iron body
- Flanged ends per ANSI B16.5
- SS304 perforated screen
- Bolted cap with clean out plug
- Upstream/downstream 1/4" plugged test ports
- 3/4" side port with plug



Material

	Part	Material	Specification
1	Body	Cast Iron / Ductile Iron ¹	A126-B / A536 ¹
2	Screen	Stainless Steel	SS304
3	Bonnet	Cast Iron / Ductile Iron ¹	A126-B / A536 ¹
4	Plug	Steel	-
5	Cap Bolt	Steel	-
6	Gasket	EPDM	-

¹ Ductile iron A536 for 8" and above

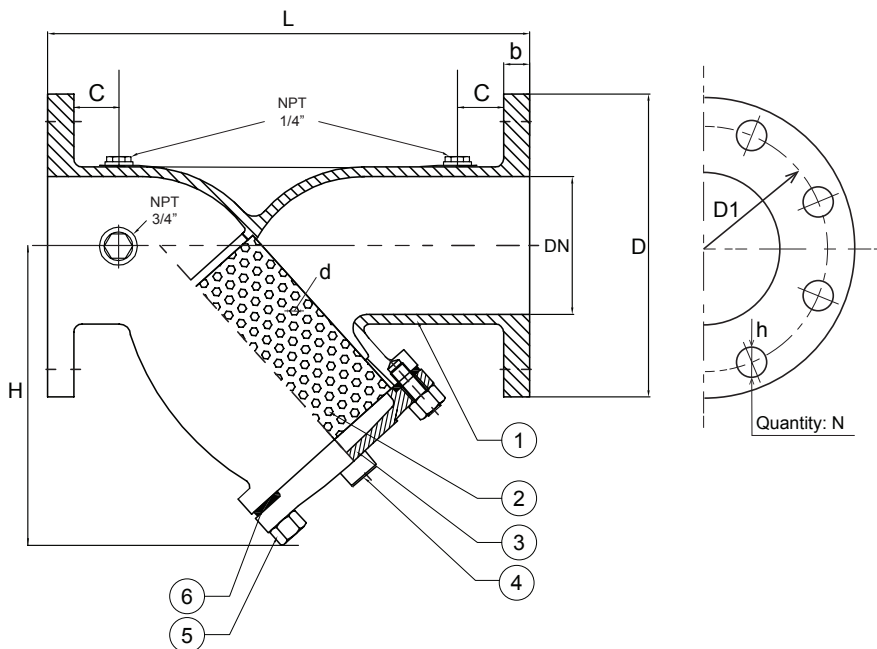

Dimension, Weight

Size	D	D1	H	L	b	C	d	N - h	Clean out	Cv	Wt.
DN	[in]	[in]	[in]	[in]	[in]	[in]	[in]	[in]	[in]		[lb]
2½"	7.01	5.51	5.91	10.75	0.71	1.18	0.039	4 - 0.75	1	80	23.6
3"	7.52	5.98	6.89	11.50	0.79	1.18	0.039	4 - 0.75	1	116	33.0
4"	9.02	3.58	7.68	13.86	0.79	1.18	0.118	8 - 0.75	1¼	205	46.5
5"	10.00	8.50	9.25	16.54	0.87	1.18	0.118	8 - 0.88	1¼	325	65.4
6	10.98	9.49	10.83	18.50	0.94	1.18	0.118	8 - 0.88	1½	465	92.3
8"	13.50	11.77	13.78	21.38	0.94	1.18	0.118	8 - 0.88	1½	845	132