

Feature

- 200# WOG
- Brass body
- Brass seat
- FNPT x FNPT
- Threaded ends (ASME B1.20.1-NPT)
- Horizontal "T" pattern



Pressure/ Temperature rating	
200# WOG	Temp. max. 450 °F

Material

	Part	Material	Specification
1	Body	Brass	ASTM B124 C37700
2	Retaining disc	Brass	ASTM B124 C37700
3	Stem	Brass *	ASTM B124 C37700
4	Bolt	Brass	ASTM B124 C37700
5	Gasket	PTFE	PTFE
6	Cap	Brass	ASTM B124 C37700

* Stainless steel stem for size 2 1/2" - 4"

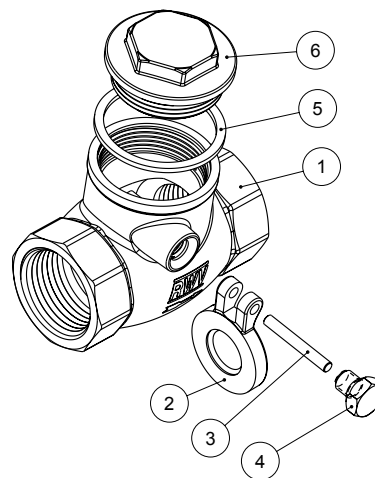

Dimension, Weight

Size	T	A	H	L	B	C	P	Wt.
		[in]	[in]	[in]	[in]	[in]	[in]	[lb]
1/2"	1/2 - 14 NPT	2.22	1.39	1.26	0.96	0.61	0.51	0.45
3/4"	3/4 - 14 NPT	2.47	1.57	2.50	1.02	0.63	0.73	0.65
1"	1 - 11.5 NPT	3.03	1.81	1.77	1.14	0.75	0.94	1.02
1 1/4"	1 1/4 - 11.5 NPT	3.31	2.19	2.11	1.50	0.77	1.20	1.43
1 1/2"	1 1/2 - 11.5 NPT	3.62	2.42	2.44	1.61	0.77	1.42	1.92
2"	2 - 11.5 NPT	4.21	2.81	2.95	1.48	0.79	1.77	2.71
2 1/2"	2 1/2 - 8 NPT	5.63	3.48	3.74	1.81	1.06	2.24	5.81
3"	3 - 8 NPT	6.18	3.91	4.41	2.05	1.14	2.56	7.62
4"	4 - 8 NPT	7.44	4.51	5.51	2.40	1.20	3.58	12.14

