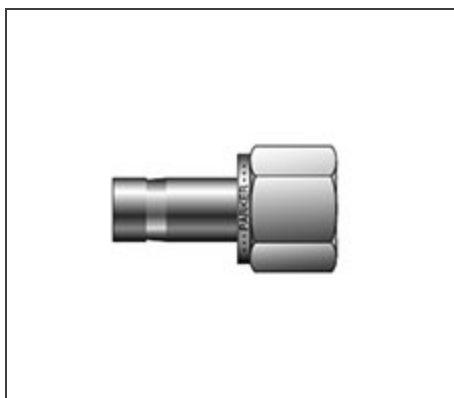

## COMPANY HEADER

## ITEM # 4-8 T2HG, TUBE END NPT FEMALE ADAPTER FOR FRACTIONAL TUBE

Parker CPI™/A-LOK® Instrumentation Tube Fittings are designed as leak-free connections for process, power and instrumentation applications. The CPI tube fittings utilize a single ferrule for easy make-up and excellent performance in vibration applications. The “spring loaded” effect of the single ferrule creates a constant tension between the fitting body and fitting nut. The A-LOK two ferrule compression tube fittings are designed to provide reliable leak-free connections for applications that

[more](#)

[Dimensions](#) | [Specifications](#)

### Dimensions

Connection Type	Tube to FNPT
Tube O.D.	1/4 in
NPT Pipe Thread	1/2
A	1.80 in
K	.63 in
W HEX	1 1/16 in
Bore	.19 in
Inter-Changes With	4-TA-7-8

### Specifications

## COMPANY HEADER

## ITEM # 6-8 T2HG, TUBE END NPT FEMALE ADAPTER FOR FRACTIONAL TUBE

Parker CPI™/A-LOK® Instrumentation Tube Fittings are designed as leak-free connections for process, power and instrumentation applications. The CPI tube fittings utilize a single ferrule for easy make-up and excellent performance in vibration applications. The “spring loaded” effect of the single ferrule creates a constant tension between the fitting body and fitting nut. The A-LOK two ferrule compression tube fittings are designed to provide reliable leak-free connections for applications that

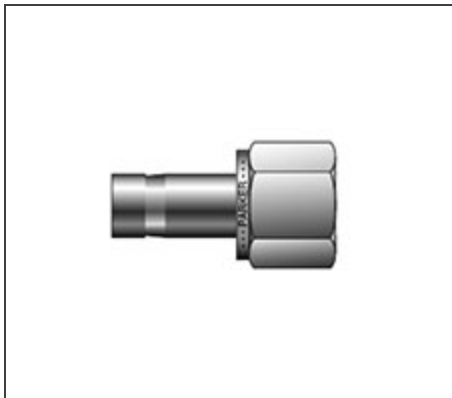
[more](#)

[Dimensions](#) | [Specifications](#)

### Dimensions

Connection Type	Tube to FNPT
Tube O.D.	3/8 in
NPT Pipe Thread	1/2
A	1.84 in
K	.69 in
W HEX	1 1/16 in
Bore	.28 in
Inter-Changes With	6-TA-7-8

### Specifications

## Features

The Parker CPI™/A-LOK® tube fitting has been specifically designed for use on instrumentation, process and control systems, analyzers and environmental equipment employed in chemical, petroleum, power generating and pulp and paper plants. CPI™/A-LOK® fittings have also been used extensively in other applications and industries wherever high reliability and quality are required.

## Material

Parker CPI™/A-LOK® fittings are available as standard in Heat Code Traceable, 316 stainless steel. Other materials include steel, brass, aluminum, nickel-copper, Hastelloy C®, Alloy 600, Titanium, 6Mo, Incoloy 625 and 825. The raw materials used fully conform to the chemical requirements listed in the Typical Raw Material Specifications Table found in the catalog. For nuclear and other critical applications, stainless steel CPI™/A-LOK® fittings are readily available with documented heat code traceability.

## Pipe Fittings/Adapters

Parker CPI™/A-LOK® tube fittings are available in combination with a variety of ISO and ANSI pipe thread configurations. For a full listing of these fittings, see Parker Catalog 4260.

## Tubing

Parker CPI™/A-LOK® tube fittings can be used with a wide variety of tubing materials and a broad range of tube wall thicknesses. CPI™/A-LOK® seals equally well on both thin wall and heavy wall tubing. **Tubing and fitting materials should be selected to be compatible with the fluid media. Due to thermal expansion characteristics and chemical stability, the tubing should be of the same material as the fitting. (The exception is brass fittings and copper tubing.)**

## Torque

Parker CPI™/A-LOK® tube fittings do not twist the tubing during installation. CPI™/A-LOK® ferrule designs assure that all make and remake motion is transmitted axially to the tubing. Since no radial movement of the tubing occurs, the tubing is not stressed. The mechanical integrity of the tubing is maintained.

**No Distortion**

In make-up, there is no undue force in an outward direction to distort the fitting body or ferrules to cause interference between the ferrules and nut. This assures that the nut will back-off freely for disassembly and permits a greater number of easy remakes.

**Sealing**

Positive, reliable connections with Parker CPI™/A-LOK® fittings have been qualified by exhaustive tests and over four decades of experience in the manufacture of quality tube fittings.

**Nomenclature**

Parker CPI™/A-LOK® fitting part numbers are constructed from symbols that identify the size and style of the fitting and material used.

**Assembly, Remake, Gaugeability**

Proper assembly is the key component to a leak-free system. CPI™/A-LOK® tube fitting assembly, remake and gaugeability instructions are found in the Parker Catalog.

**Pressure Rating & Tubing Selection**

**For working pressures of CPI™/A-LOK® tube connections, please see the Instrument Tubing Selection Guide (4200-TS) found in the Technical Section of your Parker Instrumentation Products Process Binder, or the Parker Instrument Tube Fitting Installation Manual (Bulletin 4200-B4). In cases where a male or female pipe thread is the second end of a Parker CPI™/A-LOK® fitting, such threads may be the pressure limiting factor of the tubing system. Pressure ratings for Pipe Ends are shown in this manual.**