

DEH41721 INSTALLATION INSTRUCTIONS

Clear Arc Shield Replacement Kit

Line Shields



Hazards of electrical shock or burn! Turn off power before working inside this equipment.

Used with:

30-1200 Ampere General & Heavy Duty Switches.

KIT CONTENETS			
Kit#	Seq	Description	Qty
THSHLD0	1	Arc Shield	1
	2	#10-16, Self-Tapping Screw	1
THSHLD1	1	Arc Shield	1
	2	#10-16, Self-Tapping Screw	2
THSHLD3	1	Arc Shield	1
	2	#10-16, Self-Tapping Screw	2
THSHLD4	1	Arc Shield	1
	2	#10-16, Self-Tapping Screw	2
THSHLD5A THSHLD6A	1	Arc Grid Cover Assembly	3
	2	Line Shield	3
	3	#10-14 X3/4L, Self-Tapping Screws (For Arc Grid Cover)	6
	4	#10-14 X5/8L, Self-Tapping Screws (For Line Shield)	3
THSHLD6	1	LINE SHIELD	1
	2	#10-32, Screws	2

For 30-600A SWITCHES:

Remove existing Arc Shield from Safety Switch by removing qty. (2) or (1) Screws and save mounting hardware.

Note: For THSHLD6 Only, Keep existing line shield for reassembly.

Kit-THSHLD0: Step1

Arc Shield to be mounted by aligning square hole on barrier with projection on switch base and by using new or old (saved hardware) qty. (1)#10-16 screw with torque 15In-lbs as shown in Fig1.

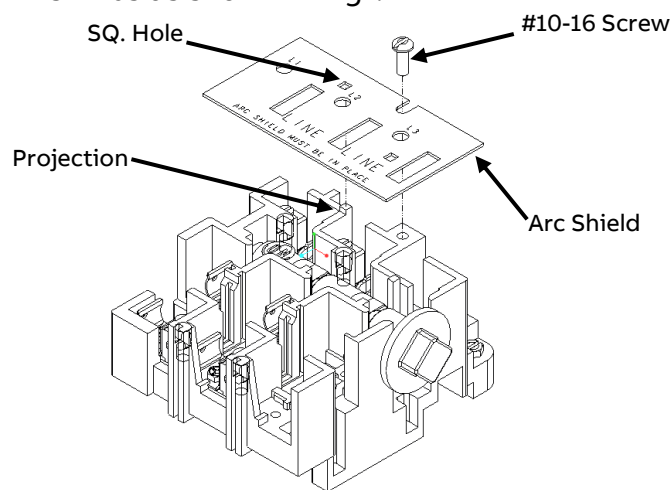

Figure 1. : Arc Shield THSHLD0 for Safety Switch

Kit-THSHLD1: Step1

Arc Shield to be mounted on Switch base by Using new or old (saved hardware) qty. (2) #10-16 screws with torque 15 In-lbs as shown in Fig2.

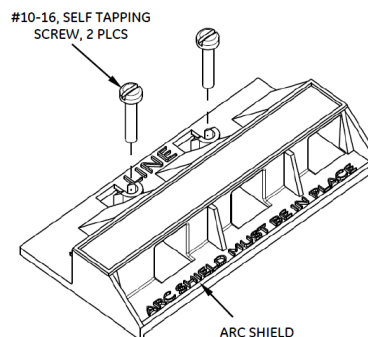

Figure 2. : Arc Shield THSHLD1 for Safety Switch

Kit - THSHLD3: Step 1

Arc Shield to be mounted on Switch Base by using new or old (saved hardware) qty. (2) #10-16 screws. with torque 15 In-lbs as shown in Fig 3.

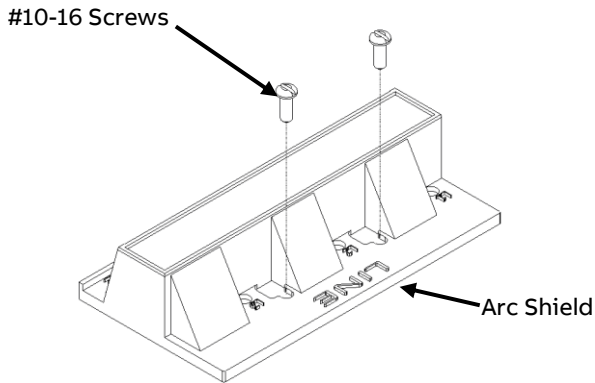

Figure 3. : Arc Shield THSHLD3 for Safety Switch

Kit - THSHLD4: Step 2

Arc Shield assembly to be mounted on Switch Base by new or old (saved hardware) qty (2) #10-16 screws with torque 15 In-lbs as shown in Fig 5.

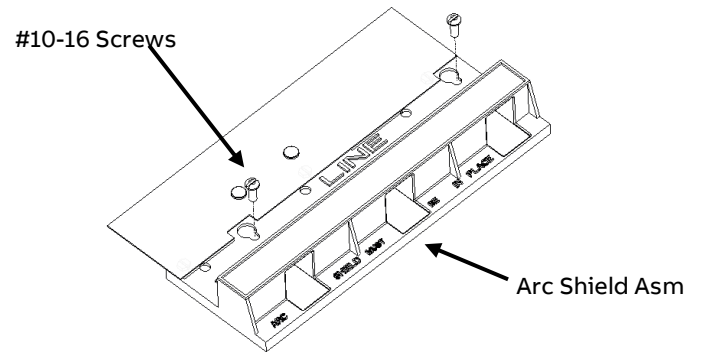

Figure 5. : Arc Shield THSHLD4 for Safety Switch

Kit - THSHLD4: Step 1

Phase barrier mounted to bottom of Arc shield extension. It must be folded into U-shape along score lines as shown in Fig 4 before assembling to Switch Base.

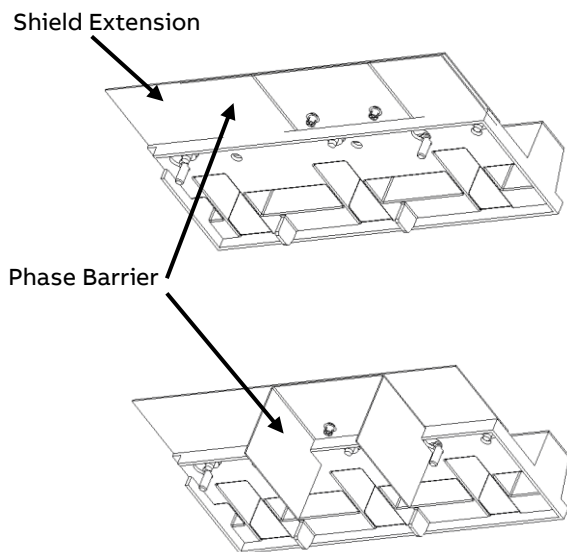

Figure 4. : Arc Shield THSHLD4 for Safety Switch

Kit - THSHLD5A & THSHLD6A: Step 1

Arc Shield assembly to be mounted on Switch pole assembly by new qty (2) #10-14 screws with torque 15 in-lbs as shown in Fig 6.

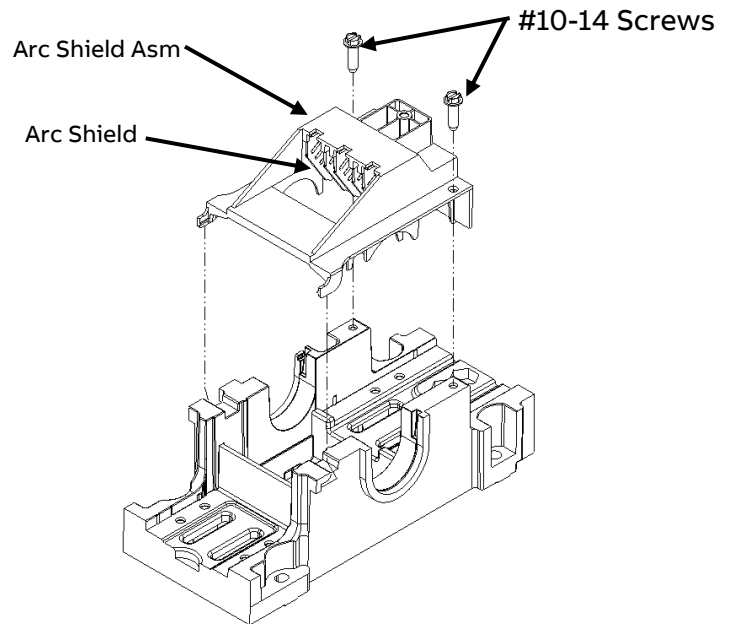

Figure 6. : Arc Shield Assembly THSHLD5A & THSHLD6A for Safety Switch

Kit - THSHLD5A & THSHLD6A: Step 2

Repeat Step 1 for remaining poles as shown in Fig 7.

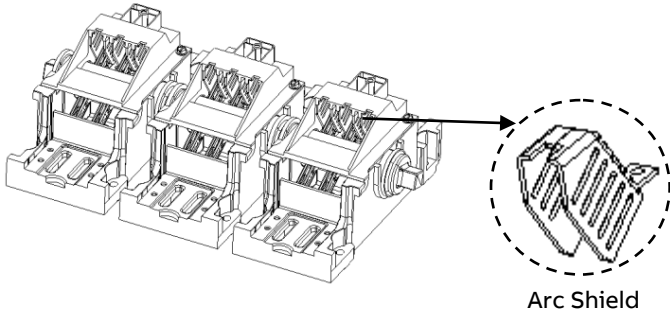

Figure 7. : Arc Shield Assembly THSHLD5A & THSHLD6A for Safety Switch

Note: Arc Shield quantity per Phase varies on Amperage (pre-assembled)

400A: 2 qty/PH

600A: 3 qty/PH

Kit - THSHLD5A & THSHLD6A: Step 3

Line Shield to be mounted on Arc Shield assembly by new qty (1) #10-14 screw with torque 15 in-lbs as shown in Fig 8.

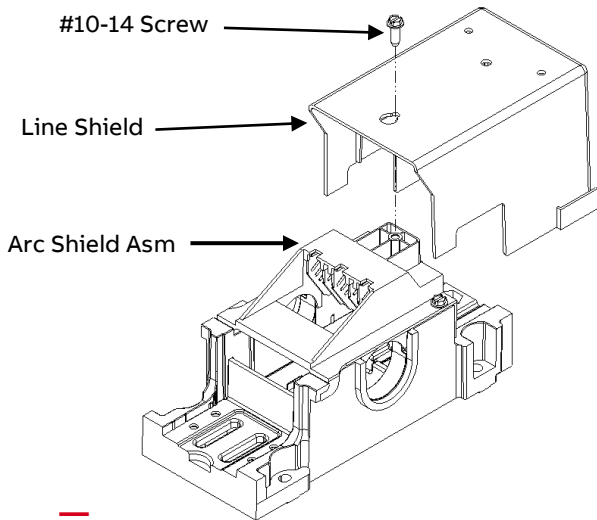

Figure 8. : Line Shield THSHLD5A & THSHLD6A for Safety Switch

Kit - THSHLD5A & THSHLD6A: Step 4

Repeat Step 3 for remaining poles as shown in Fig 9.

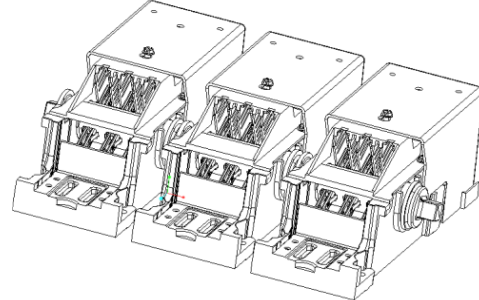

Figure 9. : Line Shield THSHLD5A & THSHLD6A for Safety Switch

Kit - THSHLD6: Step 1

New Line Shield along with existing Line shield to be mounted on Switch by new or old (saved hardware) qty (2) #10-32 screws with torque 15 in-lbs as shown in Fig 10.

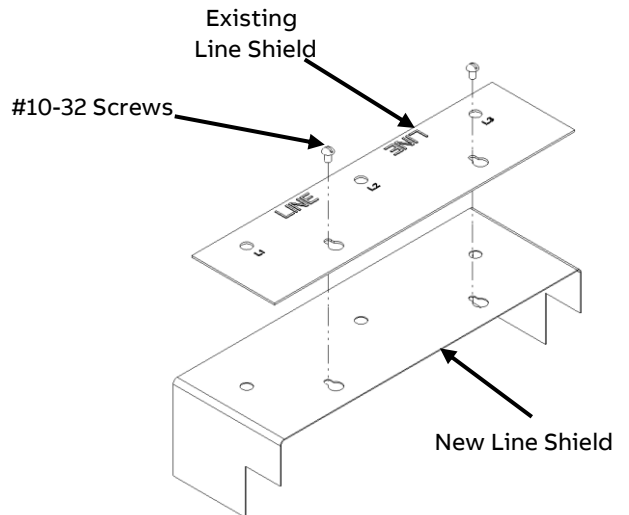

Figure 10. : Arc Shield TLSKA for Safety Switch