

**Feature**

- DZR brass body
- Blow-out proof stem
- Adjustable packing nut
- Suitable for 9500, 9700 & 9900 series valves



- Available in:
- FNPT end (ASME B1.20.1 - NPT) x Swivel nut NPSM
  - Solder end (ASME B16.22) x Swivel nut NPSM
  - Press end x Swivel nut NPSM
  - PEX (F1960) x Swivel nut NPSM

400WOG

**Working conditions:**

- Water: from 15°F to 260°F
- below 32°F only for water with added antifreezing fluids
- over 212°F only for water with added anti-boiling fluids

**Material**

	Part	Material	Specification
1	Body	DZR Brass	UNS C35330
2	Fixed end	DZR Brass	UNS C35330
3	Ball	Brass/Cr plated	ASTM B124 C37700
4	Seat	PTFE	-
5	Handle	Steel / Dc plated	ASTM A36
6	Nut	Steel / Zn plated	ASTM A36
7	Packing nut	Brass	ASTM B124 C37700
8	Packing ring	PTFE	-
9	O-ring	EPDM Perox	NSF approved
10	Stem	DZR Brass	UNS C35330
11	Joint for nut	DZR Brass	UNS C35330
12	Union Nut	Brass	ASTM B283 C37700

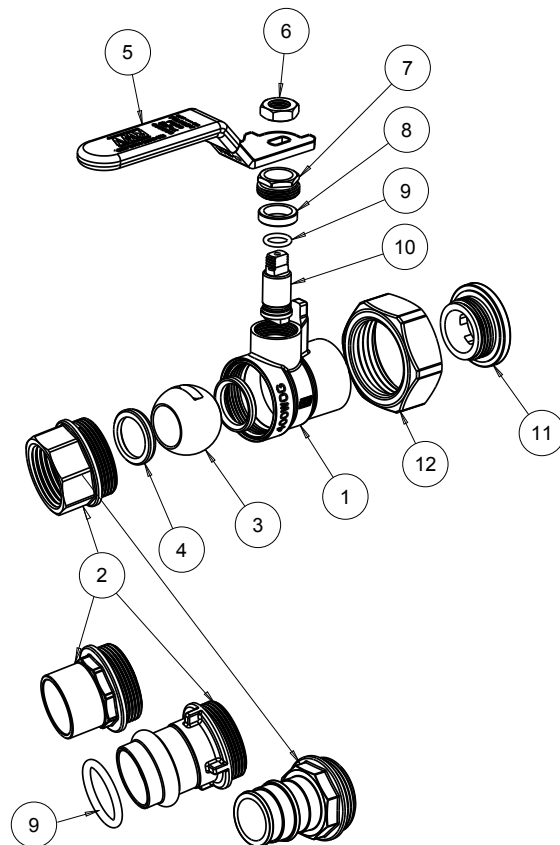

Dimension, Weight

FNPT end x Swivel nut NPSM

Size	N	P	A [in]	B [in]	D [in]	L [in]	H [in]	Wt. [lb]
1/2"	1/2 - 14 NPT	3/4 - 14 NPSM	2.45	4.96	2.17	3.58	1.93	0.51
	1/2 - 14 NPT	1 - 11.5 NPSM	2.48	4.99	2.17	3.58	1.93	0.55
3/4"	3/4 - 14 NPT	1 - 11.5 NPSM	2.72	5.11	2.40	3.58	2.07	0.71
	3/4 - 14 NPT	1 1/4 - 11.5 NPSM	2.72	5.11	2.40	3.58	2.07	0.77
1"	1 - 11.5 NPT	1 1/4 - 11.5 NPSM	3.35	6.86	3.03	4.96	2.35	1.21
	1 - 11.5 NPT	1 1/2 - 11.5 NPSM	3.43	6.94	3.03	4.96	2.35	1.26
1 1/4"	1 1/4 - 11.5 NPT	1 1/2 - 11.5 NPSM	3.86	7.17	3.50	4.96	2.59	1.62
	1 1/4 - 11.5 NPT	2 - 11.5 NPSM	3.94	7.25	3.50	4.96	2.59	1.86
1 1/2"	1 1/2 - 11.5 NPT	2 - 11.5 NPSM	4.17	7.96	3.74	5.55	2.88	2.53
	1 1/2 - 11.5 NPT	2 1/2 - 8 NPSM	4.29	8.08	3.74	5.55	2.88	3.02
2"	2 - 11.5 NPT	2 1/2 - 8 NPSM	4.92	8.43	4.37	5.55	3.25	4.04

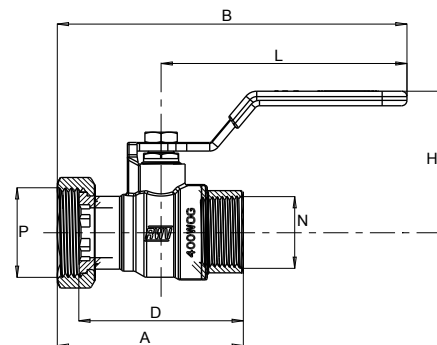

Solder end x Swivel nut NPSM

Size	C	P	A [in]	B [in]	D [in]	L [in]	H [in]	Wt. [lb]
1/2"	0.627 - 0.631	3/4 - 14 NPSM	2.47	4.96	2.19	3.58	1.93	0.50
	0.627 - 0.631	1 - 11.5 NPSM	2.50	4.99	2.19	3.58	1.93	0.55
3/4"	0.877 - 0.881	1 - 11.5 NPSM	2.94	5.11	2.63	3.58	2.07	0.70
	0.877 - 0.881	1 1/4 - 11.5 NPSM	2.94	5.11	2.63	3.58	2.07	0.76
1"	1.128 - 1.131	1 1/4 - 11.5 NPSM	3.61	6.86	3.30	4.96	2.35	1.18
	1.128 - 1.131	1 1/2 - 11.5 NPSM	3.69	6.94	3.30	4.96	2.35	1.23
1 1/4"	1.378 - 1.381	1 1/2 - 11.5 NPSM	4.12	7.17	3.77	4.96	2.59	1.54
	1.378 - 1.381	2 - 11.5 NPSM	4.20	7.25	3.77	4.96	2.59	1.78
1 1/2"	1.628 - 1.632	2 - 11.5 NPSM	4.52	7.96	4.10	5.55	2.88	2.48
	1.628 - 1.632	2 1/2 - 8 NPSM	4.65	8.08	4.10	5.55	2.88	2.97
2"	2.128 - 2.132	2 1/2 - 8 NPSM	5.54	8.43	4.99	5.55	3.25	4.01

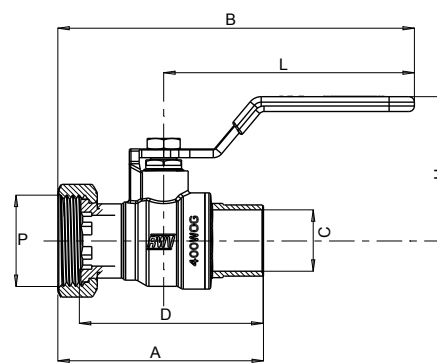

EzPress end x Swivel nut NPSM

Size	C	P	A [in]	B [in]	D [in]	L [in]	H [in]	Wt. [lb]
1/2"	0.64	3/4 - 14 NPSM	2.98	4.96	2.70	3.58	1.93	0.52
	0.64	1 - 11.5 NPSM	3.01	4.99	2.70	3.58	1.93	0.58
3/4"	0.89	1 - 11.5 NPSM	3.44	5.11	3.13	3.58	2.07	0.75
	0.89	1 1/4 - 11.5 NPSM	3.44	5.11	3.13	3.58	2.07	0.80
1"	1.14	1 1/4 - 11.5 NPSM	3.96	6.86	3.64	4.96	2.35	1.21
	1.14	1 1/2 - 11.5 NPSM	4.04	6.94	3.64	4.96	2.35	1.26
1 1/4"	1.39	1 1/2 - 11.5 NPSM	4.41	7.17	4.06	4.96	2.59	1.58
	1.39	2 - 11.5 NPSM	4.49	7.25	4.06	4.96	2.59	1.82
1 1/2"	1.46	2 - 11.5 NPSM	5.04	7.96	4.61	5.55	2.88	2.59
	1.46	2 1/2 - 8 NPSM	5.16	8.08	4.61	5.55	2.88	3.08
2"	1.95	2 1/2 - 8 NPSM	6.06	8.43	5.51	5.55	3.25	4.07

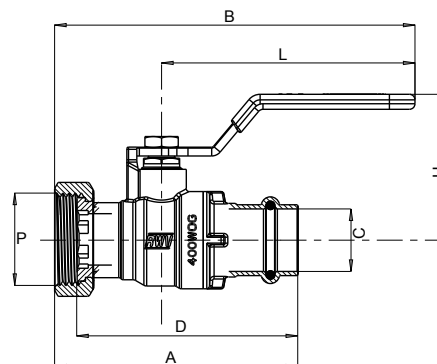

PEX (F1960) end x Swivel nut NPSM

Size	C	P	A [in]	B [in]	D [in]	L [in]	H [in]	Wt. [lb]
1/2"	1/2 - PEX (F1960)	3/4 - 14 NPSM	2.67	4.52	2.38	3.20	1.54	0.41
	1/2 - PEX (F1960)	1 - 11.5 NPSM	2.70	4.56	2.38	3.20	1.54	0.47
3/4"	3/4 - PEX (F1960)	1 - 11.5 NPSM	3.13	4.99	2.81	3.59	2.00	0.67
	3/4 - PEX (F1960)	1 1/4 - 11.5 NPSM	3.13	4.99	2.81	3.59	2.00	0.72
1"	1 - PEX (F1960)	1 1/4 - 11.5 NPSM	3.70	5.07	3.39	3.59	2.13	1.03
	1 - PEX (F1960)	1 1/2 - 11.5 NPSM	3.78	5.15	3.39	3.59	2.13	1.07
1 1/4"	1 1/4 - PEX (F1960)	1 1/2 - 11.5 NPSM	4.23	6.78	3.86	4.97	2.35	1.43
	1 1/4 - PEX (F1960)	2 - 11.5 NPSM	4.31	6.86	3.86	4.97	2.35	1.66
1 1/2"	1 1/2 - PEX (F1960)	2 - 11.5 NPSM	5.06	7.09	4.63	4.97	2.59	2.00
	1 1/2 - PEX (F1960)	2 1/2 - 8 NPSM	5.18	7.21	4.63	4.97	2.59	2.48
2"	2 - PEX (F1960)	2 1/2 - 8 NPSM	6.17	8.04	5.65	5.56	3.02	4.01

