

Feature

- 150# WSP / 600# WOG
- Brass body
- Full port
- FNPT x MNPT
- Threaded ends (ASME B1.20.1-NPT)
- Chrome plated ball
- Virgin PTFE seats
- Blow-out proof stem
- FKM O-ring packing
- CSA 1/2 psi for Natural gas, Propane & LPG service



Meet BAA requirement

Pressure/ Temperature rating	
600 psi from 15 °F to 160 °F	150 psi max. at 366 °F

Material

	Part	Material	Specification
1	Body	Brass	ASTM B283 C37700
2	End piece	Brass	ASTM B283 C37700
3	Ball	Brass / Cr plated	ASTM B124 C37700
4	Seat	PTFE	PTFE
5	Stem	Brass	ASTM B124 C37700
6	O-ring	FKM	NSF approved
7	Handle	Steel / Dacromet® plated	ASTM A36
8	Handle nut	Steel / Dacromet® plated	ASTM A36

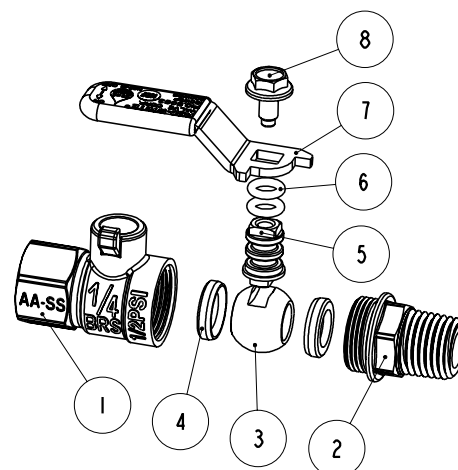

Dimension, Weight

Size	ϕ	$\phi 1$	A [in]	A1 [in]	C [in]	C1 [in]	H [in]	L [in]	P [in]	Wt. [lb]
1/4"	1/4 - 18 NPT	1/4 - 18 NPT	1.89	0.79	0.45	0.45	1.09	1.61	0.31	0.18

